



FLYING LOGIC

Thinking with Flying Logic

Robert McNally



© 2007 Sciral

Under the copyright laws, this document may not be copied, in whole or in part, without the written consent of Sciral.

Sciral
157 N. Glendora Ave. #209
Glendora, CA 91741
flyinglogic.com

Contents

Part I — Introduction	5
About This Book	5
Keys to Great Thinking	7
Part II — The Theory of Constraints Thinking Processes	11
Overview of the Theory of Constraints	13
The Goal	13
The Constraint	13
The Five Focusing Steps	14
The Categories of Legitimate Reservation	17
Clarity	17
Entity Existence	19
Causality Existence/Cause-Effect Reversal	20
Insufficient Cause	21
Additional Cause	22
Predicted Effect	23
Tautology	24
Current Reality Tree	25
Evaporating Cloud — Conflict Resolution	35
Future Reality Tree	43
Prerequisite Tree	55
Transition Tree	61
Strategy & Tactics Tree	69
Part III — Other Techniques	75
Evidence-Based Analysis	77
Concept Maps	81
Appendix	83
Resources	83
Flying Logic Web Site	83
Web Sites on the TOC	83
Books on the TOC	83
Books on Psychology, Communication, and Negotiation	84
Other Useful Web Sites	84

Part I — Introduction

About This Book

Flying Logic is software that *helps people improve*. This book, *Thinking with Flying Logic*, introduces the core techniques that the Flying Logic was designed to support. Even if you don't use Flying Logic, I hope you will find it a concise and useful introduction to some powerful ways you can improve your business and personal life.

Thinking with Flying Logic is companion to two other documents: *Welcome to Flying Logic* explains why Flying Logic exists, and the *Flying Logic User's Guide* explains the details of operating it. To use a travel analogy, *Welcome to Flying Logic* hopefully got you interested in taking a trip, the *Flying Logic User's Guide* taught you how to drive the car, and *Thinking with Flying Logic* is the road map you will follow to get you where you want to go.

However, *Thinking with Flying Logic* is not an exhaustive tutorial on the techniques it discusses— in fact, it barely scratches the surface. In particular, the Theory of Constraints (TOC) and the TOC Thinking Processes that inspired the creation of Flying Logic are supported by a wealth of literature, books, papers, web sites, courses, conferences, consultants, trainers, academics, implementors, studies, and success stories. I believe that Flying Logic is a much-needed piece of the puzzle, and I urge anyone who reads this book to seek out these other great resources as well, some of which are listed in the [Appendix](#).

Keys to Great Thinking

Most of this book is spent on the step-by-step instructions for working with each of the techniques it presents, but in this introduction I want to briefly touch on some ideas, attitudes, and behaviors that I have found create a mind set conducive to effective thinking and communication— these are the ultimate keys to effective use of Flying Logic.

Logic and Emotion

“Logic” is popularly seen as a cold, complex topic; on par with higher mathematics and invoking images of nerdy professors, science fiction computers and emotionless aliens. But the fact remains that we *all think*, and we all use logic with more or less skill.

What is not widely understood is that logic is simply the *rules for thinking*. Just as it is possible (though perilous) to drive a car without knowing the rules of the road, it is possible to think without understanding the rules of logic. These rules are extremely powerful, and fortunately quite simple— but it is unfortunate that as children we are rarely taught to use them as naturally as we learn to read and write. And far from turning us into dispassionate machines, we humans are naturally the happiest and most productive when our emotional hearts and logical minds work together in concert.

Some people resist “being logical” on the grounds that they “just know how they feel” on a given subject. But when we experience strong emotions or gut instincts, it is important to recognize that there are always underlying *causes* for those feelings. If we merely acknowledge the resulting feelings, and resist a deeper understanding of the causes, we create a disconnect between the rational and emotive parts of our minds. This disconnect results in *cognitive dissonance*, which is stress resulting from attempting to believe conflicting things or behave in conflicting ways. Cognitive dissonance is a two-edged sword: on the one hand it can help motivate us to change our beliefs for the better (that is, to better reflect reality) while on the other hand it can also lead us to manufacture *rationalizations* for the way we feel that don’t reflect reality. While both actions quell the discomfort of cognitive dissonance in the short term, rationalizing ultimately leads us deeper into trouble by putting us further and further out of sync with reality.

Attempting to act on feelings alone has another drawback: such actions leave us vulnerable to unintended consequences that our rational minds could have helped us predict and avoid. Of course, it works the other way too: if we try to be “purely rational,” yet ignore strong feelings *by discounting their causes*, we are also going to create dissonance.

The solution is to get in the habit of bringing the causes (or *reasons*) that underlie our emotions and instincts to the surface. In doing so, we validate our emotions, and can then integrate them into effective plans.

The good news is that thinking is a *learnable skill* that improves with practice, and that doing so does not diminish, but rather *complements* the value of emotions.

Communication and Criticism

We can rarely accomplish anything of significance alone: we rely on other people for many kinds of contributions, and since no one is an island, we must communicate effectively with others— to gain an understanding of their needs, benefit from their experience and wisdom, and negotiate their cooperation.

Often, we are too close to a situation to understand it well— we are embroiled in the situational details and “can’t see the forest for the trees.” When we think we understand a situation well; when we think we already know the all the options and the right answers— this is when inviting others to evaluate and criticize our plans can be the most valuable. Doing so lets “light and air” into our minds and helps us rid ourselves of ways of thinking that have become stale and unproductive.

Sun Tzu said, “Keep your friends close, and your enemies closer.” Ironically, the most fruitful criticism often comes from people who actively disagree with us. Abraham Lincoln, arguably the greatest United States President, is renowned for having chosen prominent members of his cabinet from those who most vehemently opposed his policies. Whether or not we ultimately agree with our critics, they can often teach us a great deal— the key is to allow our view of the world to change as we learn.

Argument and Honor

When we think of an argument, many of us envision scowls, angry gesticulation, and yelling. We imagine petty name-calling, a parade of unforgiven grievances, and other emotional power plays. Most importantly, we imagine arguing to *get our way*— to show that we are *right* and others are *wrong*. But such an interaction is not an argument— it is a *fight*. In a fight there may be winners, but there will certainly be losers, and injuries for all.

A real argument is a *shared search for truth*. In an honorable argument people can still be passionate, but they follow the rules of logic just as drivers follow the rules of the road. And even though people approach a situation from different perspectives and with different preconceptions, the positions they take should be seen as suggestions that are *ultimately intended* as win-win, even if they initially

fall far short. Indeed, even such flat statements as, “We’ll get along fine as soon as you learn to do things my way,” hint at a common objective: *getting along*.

When argument is viewed as a search for truth, it becomes possible to see adapting one’s position to new information and ideas not as weak or wishy-washy, but as a challenge to which only a mature, strong, and honorable person can rise. More pragmatically, all sides can begin to look forward to not merely *getting their way*, but *getting something better* in the form of a win-win solution.

Control and Influence

When considering how to cause change, we can imagine ourselves standing at the center of a circle. The things we can reach out and touch directly define our *span of control*. If the all changes we wish to make are entirely within our span of control, we have the power to simply go ahead and make them.

Usually, however, things are not so simple. In our mental image, the things we control are just what lies within arm’s reach— our span of control is always quite small. But just beyond our span of control lies the start of our *sphere of influence*. Although we may not be able to reach out and touch these things directly, we can still cause change by cooperating with others. For example, a business may *control* its manufacturing processes, while it can only *influence* its suppliers and customers.

The farther away objects are, the less influence we wield— until we reach a point where we have no significant influence. This marks the end of our sphere of influence.

Our sphere of influence is always much larger than our span of control, and is probably larger than we think. Most gratifyingly: causing positive changes within your sphere of influence has the desirable effect of expanding it.

Optimization and Suboptimization

When we reward people for improvements entirely within their *span of control*, what is the natural reaction? An example of this might be basing manager performance reviews solely on efficiency within their departments. The natural reaction is, of course, for them to *narrow their span of control* as much as possible— to define its boundaries as sharply from other parts of the system, and to focus entirely on efficiency within their particular component (division, department, cubicle, etc.) This behavior results in *suboptimization*, which is maximizing or fine-tuning a part of the system without considering the (often detrimental) effects of doing so on the entire system.

On the other hand, what happens when we reward people for improvements within their entire *sphere of influence*? In this case, their

desire becomes to extend their sphere of influence outwards as far as possible. As mentioned previously, acting in one's sphere of influence requires coordination and cooperation with others, which in turn encourages an awareness of the system as a whole. The end result is *optimization*, where people orchestrate their efforts together, toward the fulfillment of the system's goal.

Optimization is the outcome of *systems thinking* (looking at a system not as merely a collection of parts but as a unified whole) applied to the goal of *process improvement*.

Tools and Expectations

People have invented many useful tools that help us perceive the world accurately, arrange our knowledge, think about it logically, develop plans, and communicate effectively. Despite having these tools, we must still do the hard work of thinking, and also the hard work of implementing our plans. When new tools (such as Flying Logic) are introduced, they are often touted as labor-saving devices. But do we really do *less* work now that we have automobiles, telephones, and computers? Arguably, in our world of accelerating change, we often do *more*. So it is important to have a pragmatic understanding that the net result of new tools is not to *reduce labor*, but to *raise expectations*.

Just as spreadsheets were a boon to accounting and financial planning but did not make accountants obsolete, I hope that Flying Logic will be of significant help to systems thinkers and people with a passion for making the world and its systems better. Even more, it is my hope that Flying Logic will help get more people involved in these vital topics.

— Robert McNally, 2007

Part II – The Theory of Constraints Thinking Processes

Overview of the Theory of Constraints

The Goal

The [Theory of Constraints](#) (TOC) is an overall management philosophy originally developed by [Eliyahu M. \("Eli"\) Goldratt](#) and first popularized in his bestselling business novel [The Goal](#). He started with the idea that all real-world **systems**; whether personal, interpersonal, or organizational have a primary purpose, or **goal**. The rate at which the system accomplishes its goal is called **throughput**.

The Constraint

From the idea of throughput, it is easy to see that systems must also have at least one **constraint**: something that limits the system's throughput, which can be likened to a chain's weakest link. If a system had absolutely no constraints, it would be capable of infinite throughput. But though infinite throughput is impossible, amazing throughput gains *are* possible through the careful identification and management of a system's key constraints. The purpose of the TOC then, is to give individuals and organizations the tools they need to manage their constraints in the most effective manner possible.

Originally applied to industrial manufacturing lines, TOC principles have been successfully adapted for areas as diverse as supply chain, finance, project management, health care, military planning, software engineering, and strategy.

TOC claims that a real-world system with more than three constraints is extremely unlikely, and in fact usually only one constraint is key. Counter-intuitively, this is because the *more* complex a system becomes, the *more* interrelationships are necessary among its parts, which results in *fewer* overall degrees of freedom.

A major implication of this is that managing a complex system or organization can be made both simpler and more effective by providing managers with few, specific, yet *highly influential* areas on which to focus — maximizing performance in the areas of key constraints, or **elevating** the constraint (making it less constraining.)

The TOC was originally applied to manufacturing operations, where the constraint was usually a **physical constraint**— some sort of machine or process that formed a bottleneck in the production line. These sort of constraints are fairly easy to locate. But in the real-world situations where these constraints were **broken** (i.e. elevated to the point where they were no longer *the* constraint) it was discovered that the constraints could take on another character: the **policy constraint**. These are the "ways things have always been done" that ultimately serve to restrict the system's throughput, and they are usually due to some form of **suboptimization**— tuning

part of a system without regard to the benefit of the whole. Policy constraints are often more difficult to identify and more difficult to manage than a simple machine or physical process— more powerful tools were invented to do just that.

The Five Focusing Steps

To identify and manage constraints of all kinds, the developers of TOC defined the **Five Focusing Steps**, which describe a process of ongoing improvement. (Step Zero was later added for additional clarity.)

0. **Articulate** the goal of the system. *How do we measure the system's success?*
1. **Identify** the constraint. *What is the resource limiting the system from attaining more of its goal?*
2. **Exploit** the constraint to its fullest. *How can we keep the constraining resource as busy as possible, exclusively on what it can do that adds the most value to the entire system?*
3. **Subordinate** all other processes to the decisions made in Step 2. *How can we align all processes so they give the constraining resource everything it needs?*
4. **Elevate** the constraint. *If managing the constraining resource more efficiently does not give us all the improvement we need, then how can we acquire more of the resource?*
5. **Avoid inertia.** *Has the constraint moved to some other resource as a result of the previous steps? If so, don't allow inertia itself to become the constraint: go back to step 1.*

It is possible that, after iterating through the Five Focusing Steps a few times, that the constraint on the system's throughput moves entirely out of the system itself, and into the system's environment. An example of this would be when a manufacturer has more capacity than demand for its products. In this case, further improvement may still be possible, but doing so requires expanding the concept of the "system" to include its customers, the economy, and other factors that were originally just givens of the system's environment.

The Thinking Processes

The **Thinking Processes** emerged as TOC practitioners worked with organizations that needed to identify their core constraints and how to manage or elevate them. They needed the answers to three deceptively simple questions:

- **What** to change?
- **To what** to change?
- **How to cause** the change?

The Thinking Processes are based on the scientific method, to which

is added a simple visual language, the **Thinking Process Diagrams**, that are used for describing and reasoning about situations, arguments, and plans using the language of **Cause and Effect**. There are two basic kinds of reasoning: **Sufficient Cause** and **Necessary Condition**.

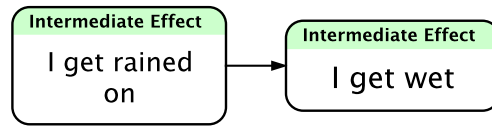

A sufficient cause for an effect

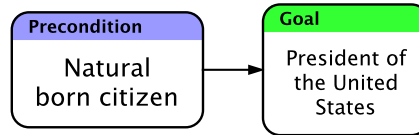

A necessary condition for an effect

The Thinking Process Tools

From the basic Thinking Processes developed several techniques called the **Thinking Process Tools** designed to answer the three questions. The tools provide the ability to develop a complete picture of a system's core constraints and how to manage them.

Tool	Thinking Process	Starting Point	End Result
Current Reality Tree (CRT)	Sufficient Cause	A set of undesirable symptoms	The core cause of the symptoms (constraint)
Evaporating Cloud	Necessary Condition	A perceived conflict underlying a constraint	Possible win-win solutions
Future Reality Tree (FRT)	Sufficient Cause	A proposed solution	Necessary changes that implement the solution and avoid new problems
Prerequisite Tree (PTR)	Necessary Condition	Major objectives and the obstacles to overcoming them	Milestones that overcome all obstacles
Transition Tree (TRT)	Sufficient Cause	A set of goals	Detailed actions to achieve the goals
Strategy & Tactics Tree (S&T)	Necessary Condition	The highest-level goals of a system	A multi-tiered set of implementation steps

The last of these tools— the **Strategy & Tactics Tree**, is used in large organizations where it is necessary to create major changes in a short period of time. However, the other five tools are applicable to systems of any size from individuals, to families, to businesses small

and large. Like a physical tool kit, you can choose to use individual tools— just the right tool for the job at hand. Or, you can do a larger project where most or all of the tools may be required. When all of the tools are used, the “finished result” of one tool can easily be used as part of the “raw materials” for the next tool. Since improvement is a continuous process, you can use each tool over and over again on every pass through the Five Focusing Steps.

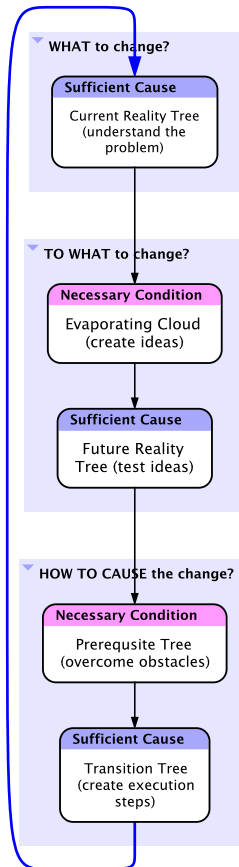

The Measurement of Success

The last piece of the improvement puzzle is *feedback*. There needs to be an unambiguous way to measure improvements brought about through the implemented changes. For traditional business, Dr. Goldratt developed three *non-traditional* measurements that began with the overriding concept of the system’s *goal*: **Throughput (T)**, **Inventory (I)**, and **Operating Expense (OE)**. It is outside the scope of this book to discuss these in detail, but readers are directed to the TOC body of knowledge (see the [Appendix](#)) for discussions of these measures and how they have been adapted for many different endeavors.

The Categories of Legitimate Reservation

We all want our ideas and plans to make sense. But how do we *know* that we are making sense? What do we even mean by that? When we use the **Thinking Process Tools**, we are building a model of the way part of the world works, and in this context our model *makes sense* if it in fact portrays a picture of the world that is *pertinent* and *accurate*.

To be *pertinent*, our model must be of that part of the world (our system) that we actually care about— in other words our model must have the proper *scope*. It must not be too detailed in areas that don't significantly affect the outcome, nor too general— glossing over areas where important details lie. To ensure pertinence, the people who are the main stakeholders in the outcome of the plan must have influence over it.

To be *accurate*, the cause-and-effect relationships that we model must indeed hold in real life. The **Categories of Legitimate Reservation** (CLR) are ways to verify the accuracy of a **Thinking Process Diagram**. They are used to catch common pitfalls in our own thinking and the thinking of others. They are called the *Categories* because they are well-defined and of limited number. They are called *Legitimate* because anyone who writes or reads logical statements is always allowed to express them. And they are *Reservations* because they highlight parts of the diagram that are not completely convincing. Since these reservations are *always legitimate*, they can be raised, explored, understood, and accepted without anyone feeling like they're having their toes stepped on— they help everyone keep their emotional distance and stay reasonable.

When you start to work with Thinking Process diagrams, you should deliberately consider the CLR one by one for each part of your diagram. But as you gain experience you will find you begin to apply them quickly and habitually.

Clarity

If you are creating a Thinking Process diagram by yourself, you probably have a good idea of what you mean. However, you will also probably need to share your plan with someone else sooner or later, and you need to apply the Clarity reservation as the *last* step before you do. Ask yourself:

- Is the meaning of each part of my diagram clear?
- Is the meaning of my diagram as a whole clear?

Similarly, when someone presents you with a Thinking Process dia-

gram you have never seen before, you should apply the Clarity reservation *first* by asking yourself:

- Does this diagram really convey what the person presenting it intends?

In Thinking Process diagrams, causes and effects are all represented by **entities**: rectangles that contain brief statements that are, or could be, true about reality. Flying Logic entities also have a colored bar at the top that designates the entity's **class**— the kind of role the entity plays in the diagram of which it is part.

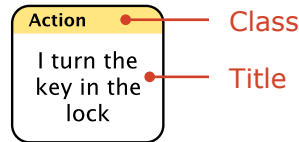

To satisfy the clarity reservation, the **title** of an entity must be:

- complete, unambiguous, and grammatically correct,
- in the present-tense, and
- *simple* in that it contains a single idea with no compound statements.

“Bumped and glass fell and broke,” is an example of a statement that violates all three principles. This idea should probably be expressed as three separate entities, each related to the next by a causal connection:

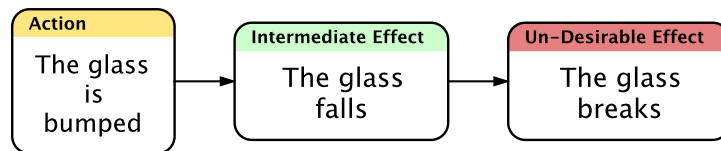

The causal connections between the entities must also be clear, with each step from entity to entity having a natural and obvious flow for any stakeholder who reads the diagram. Reading from one entity to another via an **edge** (also called an **arrow**) will follow one of two patterns, or **Thinking Processes**. Which Thinking Process is used depends on what kind of diagram you are working with; but within a single diagram, the meaning of the edges does not change.

- **Sufficient Cause Thinking:** “If **A** then **B**.” or “**A** is sufficient to cause **B**.”

This pattern expresses the idea that the existence of **A** is, by itself, enough to cause the existence of **B**. Sufficient Cause Thinking is used by the **Current Reality Tree**, **Future Reality Tree**, and

Transition Tree.

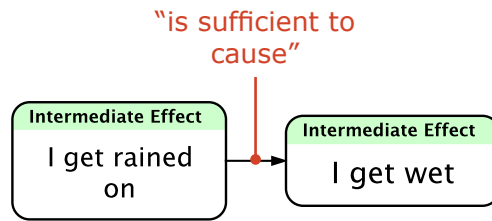

- **Necessary Condition Thinking:** "If not **A** then not **B**." or "**A** is necessary to obtain **B**."

These patterns express that **A** must exist for **B** to exist, but may not be sufficient by itself. Necessary Condition Thinking is used by the **Evaporating Cloud** and **Prerequisite Tree**.

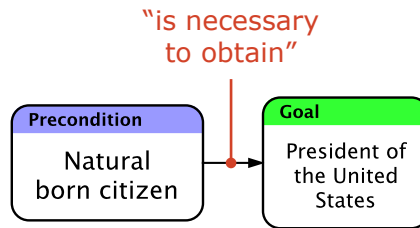

Notice that in both illustrations, the edge (arrow) looks exactly the same although the meaning is different. How you read an edge depends on which Thinking Process was used to construct the diagram.

Entity Existence

This reservation asks whether an entity in the diagram *is true now*. In a Current Reality Tree, for instance, every entity in it should describe something that *is true now*. A Future Reality Tree or Transition Tree, however, can contain a mix of entities that are either true now, or would be expected to become true under certain conditions. This reservation is a warning to "check the facts" before making an untrue assertion about reality.

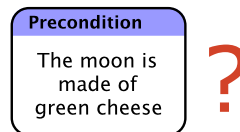

Causality Existence/Cause-Effect Reversal

This reservation asks, "Does **A** really cause **B**?" Often we associate two ideas because they are *correlated*, that is, they are often found in proximity to each other. However, to actually say that one thing *causes* another requires much stronger evidence.

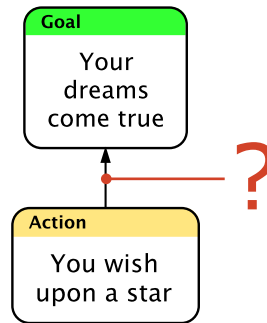

Indirect Effects

Other times, an entity is an **indirect effect** of a cause, but important necessary steps are missing.

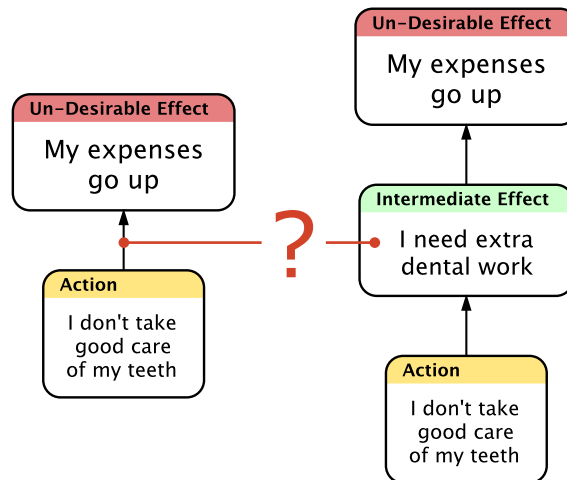

Cause-Effect Reversal

A special case of the Causality Existence reservation is **Cause-Effect Reversal**. In this case, we question whether the edge is pointed in the right direction.

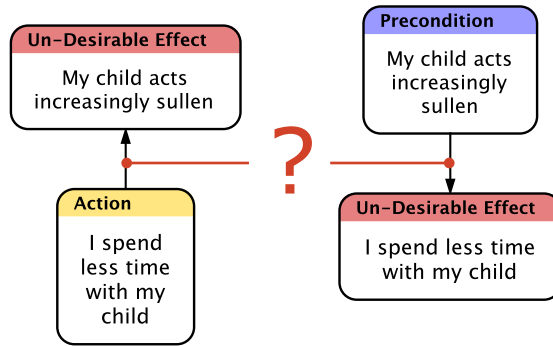

Back Edges

In cases where it seems ambiguous as to which entity is the cause and which is the effect, it may be a good place to look for a self-reinforcing loop. Flying Logic can model self-reinforcing loops using **back edges**. A back edge is added whenever you attempt to create a new edges that indirectly makes an effect to be its own cause. Back edges are drawn thicker than regular edges and in blue.

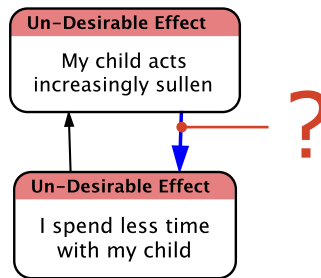

Insufficient Cause

This reservation asks, "Is **A**, all by itself, sufficient to cause **B**? What else might also be necessary?" Usually a combination of factors outside our control ("Preconditions") and factors that we influence or control ("Actions") must combine to create a particular effect. In diagrams based on Sufficient Cause Thinking, this is modeled using

a **junctor** that contains the **AND** operator. Junctors are easily created by dragging from an entity to an existing edge.

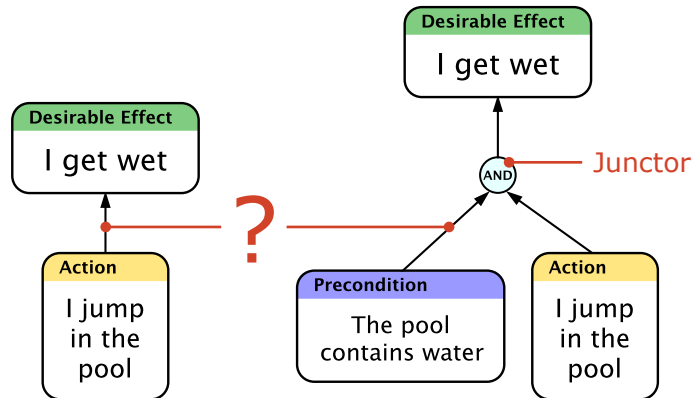

When looking for insufficient causes, we should also keep in mind that a list of causes can also be *too sufficient*, or in other words, include causes that are actually not required to produce the effect. So we should also ask, "Have we listed anything as necessary that really isn't?"

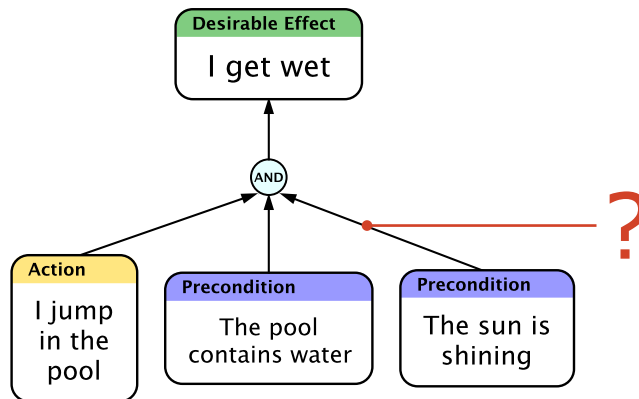

Additional Cause

Once we have identified one sufficient cause for an effect, we are often tempted to move on, and in doing so we may overlook other causes that may either be independently causing the effect, or mutually intensifying it. This reservation asks, "Have we identified every cause of **A**? What else could also be causing **A**?"

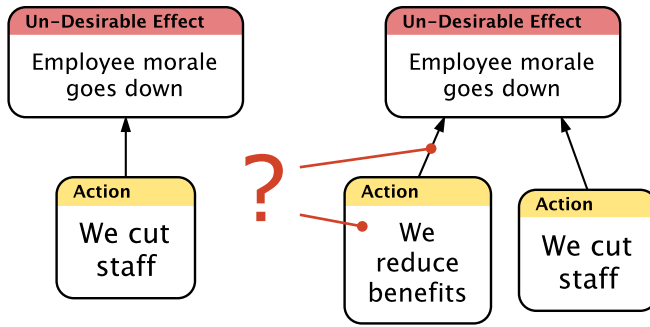

Predicted Effect

How can we increase our certainty that a cause we have identified is *really* the cause of the effects we are inclined to believe? For example, let's say I come from a walk and discover my wallet missing. One of the first things that might pass through my mind is that my house has been robbed. But *has* it been robbed?

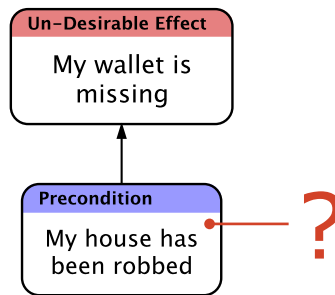

Usually a cause is responsible for more than one effect, and this reservation asks, "If **A** is true, what other effects *in addition to B* would we expect to see?"

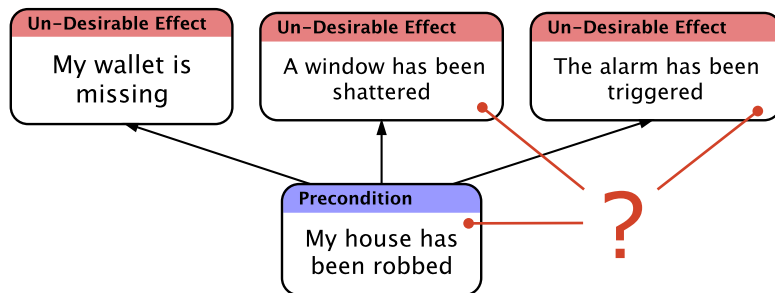

If the additional predicted effects are also observed, then we can be more confident in the causality we initially identified. But if the

predicted effects are *not* observed, then we may be well advised to look for additional causes.

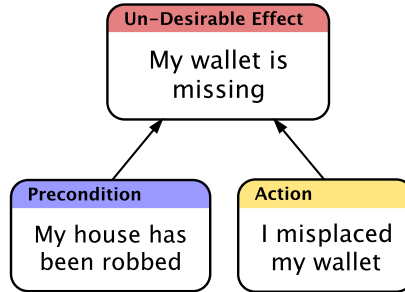

Tautology

People sometimes don't examine their beliefs very closely, and will, when asked for a cause, often re-state the cause using different words. Even though you will almost never encounter tautology (also called *circular reasoning* or *begging the question*) in a Thinking Process diagram, you will encounter it in casual conversation. Some examples:

- "You can't give me a C for this course— I'm an A student!"
- "My homework is boring because it's so tedious."
- "Mayor Green is the most successful mayor ever because he's the best mayor in our history."
- "The defendant shows no remorse, and this fact should strengthen your resolve to find him guilty!"

Current Reality Tree

When a non-trivial system (a for-profit business, a non-profit organization, a department, or a personal relationship to name a few examples) needs improvement, it is often not clear *what to change*, even to people who have a great deal of experience with the system's workings. This is because systems contain many cause-effect relationships that interrelate in complex ways, and understanding the system sufficiently to decide what to change is often even more problematic because the people with experience often have only a narrow view of the parts of the system they interact with.

The Theory of Constraints (TOC) is based on the idea that all systems have a *goal*, or reason for existence—the rate at which a system can achieve its goal is called its *throughput*. The TOC also says that all systems have *core drivers*, which can be physical constraints, policy constraints, market constraints, or some combination of those, that have a major impact on the entire system and that ultimately (albeit indirectly) govern the system's throughput. Ironically, the *more* complex the system, the *fewer* core drivers it is likely to have, due to the greater number of interdependent cause-effect relationships such systems contain.

The **Current Reality Tree** (CRT) is a tool for discovering the system's core driver, which is also known as *the constraint*. The constraint is the cause that is *most common* to the *most severe* symptoms the system is experiencing, and thus the constraint must be managed most carefully in order to most dramatically improve throughput. By focusing on the constraint, you will realize the most “bang for your buck.”

Flying Logic Setup

A CRT is based on [Sufficient Cause Thinking](#), and this is how Flying Logic documents are set up when first created, so you do not need to do anything special with the Operators popup menus to start creating your CRT. Most CRTs are drawn with root causes at the bottom and the symptoms at the top, so you may want to use the Orien-

tation popup menu to change the orientation of your document to **Bottom to Top**.

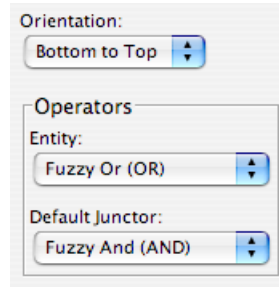

CRTs are created using the entity classes in the built-in Effects-Based Planning domain, and primarily use the following classes: Un-Desirable Effect, Precondition, and Intermediate Effect. CRTs are most often used to pinpoint problems, but can also be used to identify core strengths, in which case the Desirable Effect class can also be used.

- Effects-Based Planning
 - Goal
 - Intermediate Effect
 - Precondition
 - Action
 - Un-Desirable Effect
 - Desirable Effect

Step 1: Understand the Scope

Before you can document how your system works and where its problems lie, you need to make sure you have a clear understanding of what you mean when you talk about your system. In other words: what are you analyzing?

Spend the time necessary to reach a clear, written understanding with other stakeholders:

- What is your system's goal?
- What are the necessary conditions for knowing the goal is being achieved?
- What measures do you use to use to know how well the necessary conditions of the goal are being met?
- Where do the boundaries of your system lie?
- What greater system is your system a part of?

- What systems does your system interact with?
- What are your system's inputs and outputs?

Step 2: List the Symptoms

Presumably, you are doing your analysis because you believe the system would benefit from improvement, and because you see evidence of this potential benefit in various problems or symptoms of trouble. Such symptoms could be low profits, low customer satisfaction, or lots of arguments among family members. These symptoms are known in TOC as **Un-Desirable Effects** or simply **UDEs**.

Usually there are between 5 and 10 UDEs that are causing the most difficulty in the system, and it is these UDEs that should be added first. Give each UDE a simple, present-tense title that is intended to be clear to any stakeholder, and make sure that the UDEs you choose at this stage are uncontroversial as to their actual existence. In other words, any stakeholder who looks at this list should have no difficulty agreeing, "Yes, these are some of the most serious problems we have."

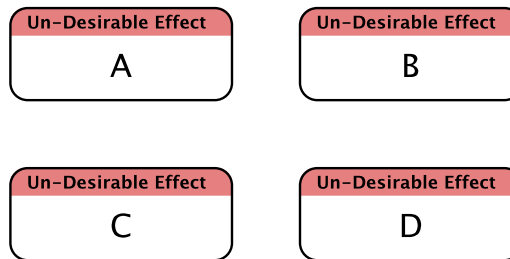

Step 3: Connect the Symptoms

Undesirable Effects are often contribute to other problems. As you study your list of UDEs, you will notice that some are probably direct or indirect causes of others already in your list. If this is the case, then connect these entities with *edges* (arrows) from the causes to the effects. Don't be too concerned at this stage if the causes are not directly responsible for the effects: as you grow the tree, you will add other entities that complete the picture.

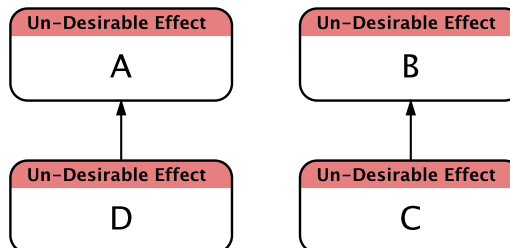

Sometimes you will notice that a single cause contributes to more than one effect, as is the case with **D**, below.

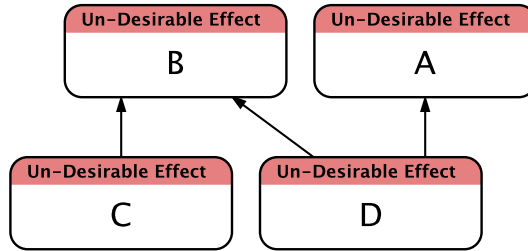

Other times you will notice that an effect has more than one independent cause, as is the case with **B**, above. When a Flying Logic document is set up for Sufficient Cause Thinking, more than one arrow entering an entity denotes more than one *sufficient, independent cause*. This is also called an **OR** relationship.

Often, a single cause is *necessary, but not sufficient* by itself to cause an effect. This is denoted by an **AND** junctor, which is created by dragging from the cause entity to an existing edge.

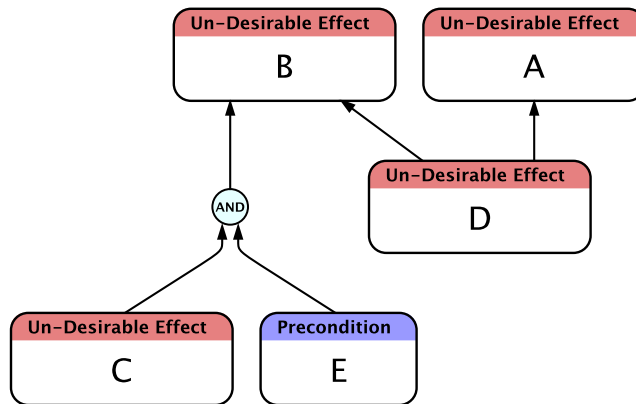

Step 4: Apply the Categories of Legitimate Reservation

The diagram as it stands is probably only an extremely rough picture of your system. By applying the [Categories of Legitimate Reservation](#), you now add additional entities and causal relationships that create a true picture of the situation. In particular, look to add *additional causes* for the effects you have identified, and identify *insufficient causes* and add their *necessary conditions*. Also review your diagram for *clarity*, and step through it using Flying Logic's confidence spinners. You can even change the class of an existing entity if, for instance, an entity that you originally added as an UDE now appears more neutral in context.

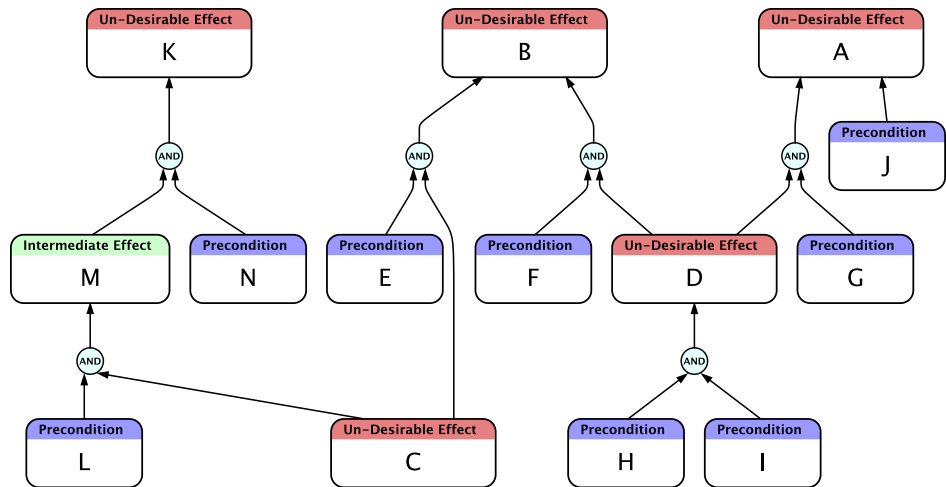

Use these guidelines to help you choose what class of entity to add:

- If an entity is undesirable on its face— in other words, if the system would definitely be better off without it, then use the **Un-Desirable Effect** class. UDEs can have predecessors, successors, or both, but should always have at least one causal connection into a completed diagram.
- If the entity is neither negative nor positive, but exists merely due to the larger context in which the system must operate and is something over which you have no significant influence, then use the **Precondition** class. Preconditions should never have predecessors, and should always have at least one successor.
- If the entity is neither negative or positive, but exists because of something within your control, then use the **Action** class. Actions are always causes and never effects, so they will have successors but no predecessors.
- If the entity is neither negative nor positive, but it exists as a consequence of other causes in the diagram, use the **Intermediate Effect** entity class. In a completed CRT, Intermediate Effects should *always* end up with both predecessors and successors.

Step 5: Continue Adding Underlying Causes

At this stage, you may have several unconnected, or loosely-connected clusters of entities. In this step, search for and add deeper causes for the effects in your diagram, looking in particular to add causes that tie two or more clusters together. Of the causes that are currently at the root of your diagram, keep asking yourself, “Why is this happening?” and make your answer take the form of additional entities and the edges that connect them. Alternate between adding underlying causes and applying the Categories of Legitimate Reser-

vation from the previous step.

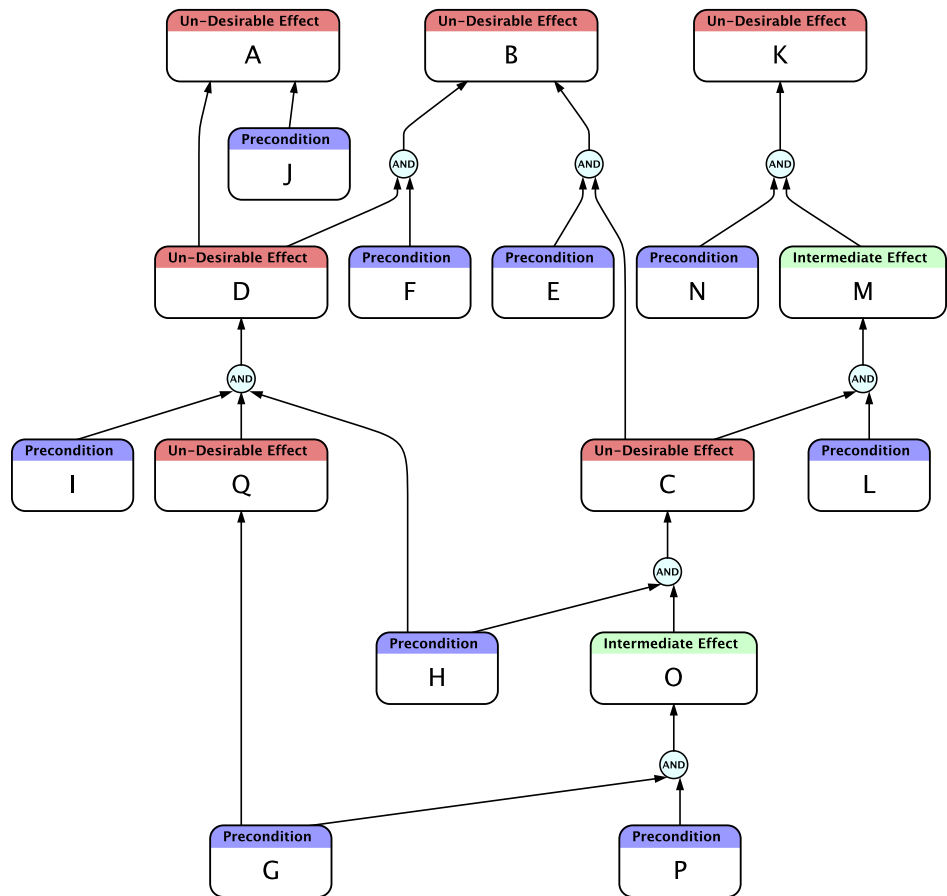

Step 6: Consider Negative Reinforcing Loops

Although it is uncommon, sometimes the presence of an UDE at a higher level in your system actually aggravates UDEs at a lower level. Since this situation is so serious, it is important that you note it in your diagram as a **causal loop**, also known as a [vicious circle](#).

Normally, all edges in a Flying Logic document “flow” from the start of the document (the root causes) to the end (final effects.) When you attempt to add an edge that would create a loop (that is, an effect indirectly becoming its own cause) Flying Logic creates a special **back edge** that denotes a causal loop. Back edges are thicker than regular edges and drawn in blue.

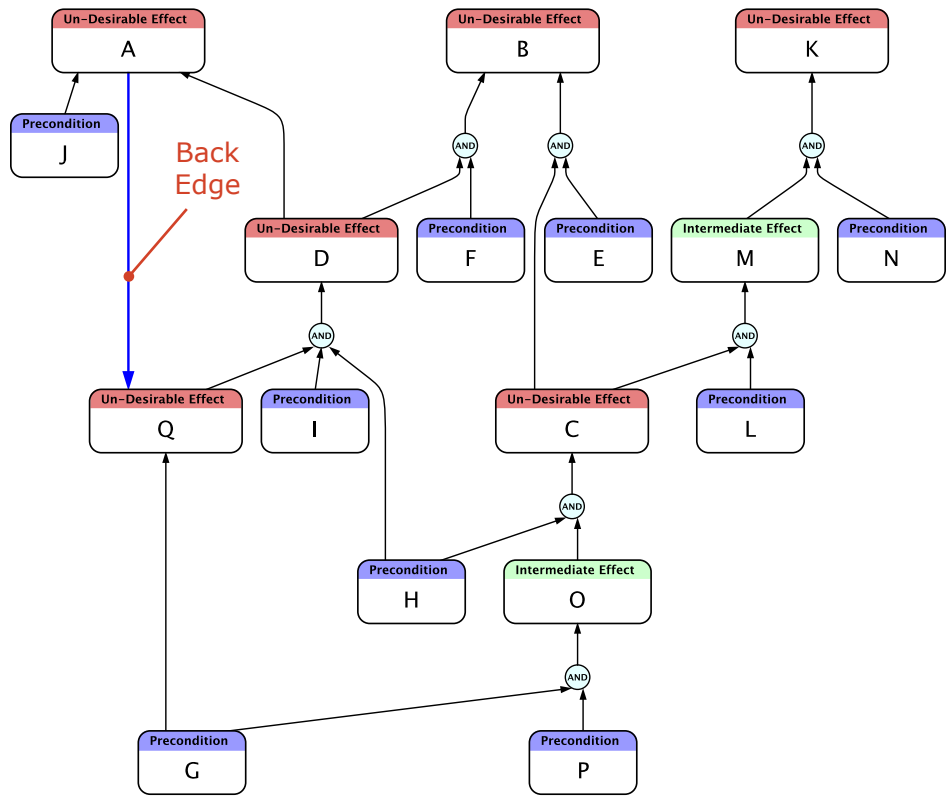

Back edges differ from regular edges in two ways: They do not have edge weights, and they do not participate in the flow of confidence values through the documents. They can, however, be annotated like other edges.

Step 7: Identify Root Causes

As your CRT becomes more complete, you will notice that one group of causes lie at its “root.” That is, they have successors but no predecessors. Some of these causes will be Preconditions and others may be UDEs, and they won’t necessarily appear at the bottom of the diagram— in the illustration above there are nine root causes.

The purpose of this step is to make sure you have built down your tree to the point where you have uncovered the deepest causes *over which you have some control or influence*. Preconditions are by definition out of our control, but you should question whether the preconditions at the root of your CRT aren’t really Intermediate Effects with other underlying causes. Also question whether the UDEs at the root of the tree don’t have additional underlying causes that you also control. The idea is to “uproot” problems at their deepest possible level.

Step 8: Trim the Tree

At times you may discover that parts of the tree you have built have little or no connection, as successors or predecessors, to the UDEs you care about. To keep the tree manageable, you should remove these clusters from view by either

- Deleting them,
- Using Cut and Paste to move them to a different document, or
- Placing them into a group which is then collapsed.

Step 9: Identify the Core Driver

If you have constructed your CRT rigorously observing the rules of cause and effect, you will agree that eliminating a root cause will also cause a chain reaction of other problems being eliminated. If this doesn't appear to be the case, go back and make sure that at each step in the diagram, you have identified and added all the *necessary* and *sufficient* causes of your UDEs (Step 4), and that you have built the tree down as far as possible to root causes that you control or influence (Step 5.)

The time has come to identify the single cause that has the most influence over the most critical UDEs in your CRT. This single cause is the Core Driver (also call the *constraint*, or the *bottleneck*)— the cause that must be managed or eliminated in order to break through the boundaries that hold your system back.

Although your CRT may contain several root causes, all of which may eventually need attention, you can find the Core Driver by judging several factors for each root cause:

- **How many** UDEs they indirectly cause,
- **How severe** are the UDEs they indirectly cause, and
- **How much control or influence** you have over them.

PRO If you use using Flying Logic Pro, you can turn on the **Edit ↗ Cut/Copy Includes Successors** switch, select one of your root causes, then select **Edit ↗ Copy**. This highlights the cause you selected, *and* all of its direct and indirect predecessors. (Press the **Escape** key to remove the highlighting.) Use this technique to quickly get an idea of how influential each of your root causes are, although you will still need take the severity of the UDEs into account.

In the illustration below, entity **G** has been selected and copied with the **Includes Successors** switch on, which makes it obvious that it contributes in some way to every UDE in the diagram. Since all of the causes in the diagram are at least within our influence, we

conclude that **G** is our Core Driver— it is the constraint on which we must focus.

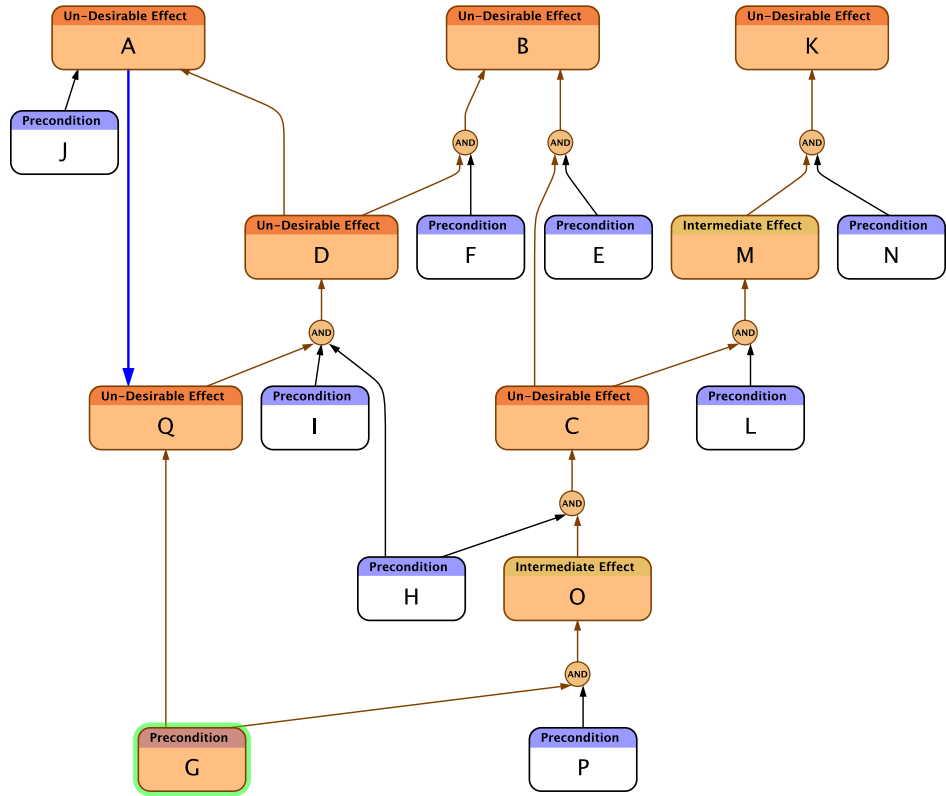

Evaporating Cloud – Conflict Resolution

Arguments. Fights. Politics. Enemies. Compromise. Loss.

We have all encountered conflict, and most of us try to avoid it whenever possible. Conflict is seen as unhealthy and unpleasant to the point that many people will attempt to ignore it even after realizing that doing so may actually be contributing to a worsening situation. Or both sides treat the conflict as a zero-sum game: “Either I go, or he goes!” Or perhaps worse, both sides compromise: they “split the baby” and nobody goes away happy.

It turns out there are better ways for resolving conflicts: ways that result in the creation of solutions that completely satisfy everyone involved. From one remarkable perspective, it is even possible to entertain the idea that *conflicts don't actually exist* except at the superficial level of our *positions*: what we say we *want*.

When two wants appear to be mutually exclusive, we say there is a conflict. The way forward is to recognize that our *wants* (also called *positions*) are motivated by underlying *needs* (also called *requirements*.) For example, the two wants could result from children fighting over a toy: in this case they both *want* to possess the same limited resource. However, they are motivated by underlying *needs*, which may not be the same for each of them: one child may feel the need to assert their ownership of the toy, while the other child may feel the need to incorporate the toy into their play. Furthermore, the children are united in a *common objective*: to get along and have fun. To achieve this common objective, satisfying both children's needs is necessary. Notice that as we have passed beyond the boundary of the apparent conflict presented by their wants, a recognition of their needs and common objective begins opening the door to creative solutions that may leave everyone happier than they thought possible.

When the connection is made that conflict stems *not* from some kind of pathology, but from *legitimate needs* and *common objectives*, it becomes obvious that the best approach is not avoidance but prompt communication and the creation of options for mutual gain.

Often, after producing a Current Reality Tree (CRT), it is possible to recast the Core Driver as a *Core Conflict*, containing two mutually exclusive positions. So whenever we find ourselves faced with conflicting wants, which often happens as the result of creating a CRT, but even more frequently just happens on its own, the **Evaporating Cloud** is the tool to use. (It is so-called due to its ability to “evaporate” conflict. It is also known as the **Conflict Resolution Diagram**.)

Flying Logic Setup

Since the basic form of a Cloud is always the same, the easiest way to start a Cloud is to open the included template file **Cloud.logic-t** located in the **Examples/Conflict Resolution** folder. Template files open as new, untitled documents to which you can make changes and save without fear of accidentally changing the template file itself.

The following paragraphs describe how to set up a Cloud document from scratch. You can skip to the next section if you are using the template.

A Cloud is based on [Necessary Condition Thinking](#). Since Flying logic documents are set up for Sufficient Cause Thinking by default you will want to set the Operator popup menus as follows:

- Entity Operator: Fuzzy And (AND)
- Default Junctor Operator: Fuzzy Or (OR)

Clouds are read from left-to-right, starting at the Common Objective. However, this means the flow of the edges (arrows) must be towards the Common Objective or right-to-left: so you will want to set the Orientation popup menu to **Right to Left**.



Clouds are created using the entity classes in the built-in Conflict Resolution domain, and use the following classes: Want, Need, Common Objective, Conflict, and Solution.

- Conflict Resolution
- Want
- Need
- Common Objective
- Conflict
- Solution

If you're using the template mentioned above, then the diagram is already drawn for you— you only need fill in the text. But the steps

below assume you are drawing a cloud from scratch.

Step 1: Identify the Wants

Create two **Wants** entities and give them titles that succinctly summarize each of the conflicting positions. Traditionally the two Wants are called **D** and **D'** ("D Prime").



Step 2: Identify the Conflict

Create a single **Conflict** entity and make it a predecessor of each of the two Wants. If you're using the right-to-left orientation typical of Clouds, the Conflict entity will be to the right of the Wants.

Give the Conflict entity a title that summarizes *why* the Wants conflict.

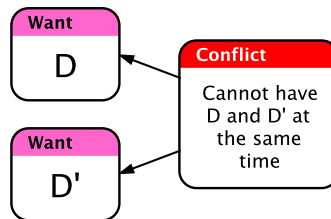

Finally, right-click (Mac or Windows) or control-click (Mac) one of the two edges leading from the Conflict entity and select **Negative** in the popup menu that appears. This causes the edge you negated to turn red. By doing this, our model accurately reflects the mutually-exclusive nature of the two wants. To see this, click the Show Confidence Spinners switch in the toolbar, then adjust the spinner on the Conflict entity from its maximum (True) to its minimum (False). You will see how the spinners on the Wants entities cannot both be true at the same time, due to the negated edge.

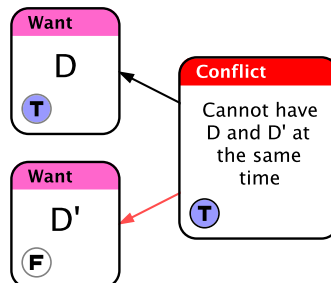

Step 3: Identify the Underlying Needs

Create two **Needs** entities, each one a successor to one of the Wants entities. The purpose of a position is to fulfill an underlying need. Give each need a title that summarizes the immediate need that its side in the conflict is trying to fulfill by asserting its position (the Want.)

The difference between a Need and a Want is simple: fulfillment of Needs are *conditions* considered necessary to fulfilling the overall objective, while Wants are particular *actions* chosen to fulfill the needs.

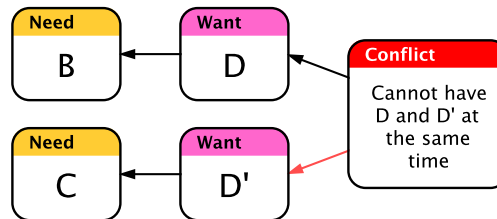

Step 4: Identify the Common Objective

Create a single **Common Objective** entity, and make it a successor of both needs. In a left-to-right orientation, the Common Objective will be the left-most entity in your diagram.

If the two sides in the conflict have no common objective, then there isn't really any conflict because the two sides could simply go their separate ways— they have no reason to cooperate. Thus, in every situation identified as a conflict, there is always a common objective. The Needs identified in the previous step are both considered *necessary* to achieving the common objective. In other words, both sides of the conflict believe that unless their needs are met, the common objective *cannot* be met.

The Common Objective is also usually at a "higher level" than the Wants or the Needs. In the case of the children fighting over a toy, the Common Objective might be for them to "get along and have fun." Notice that this Common Objective doesn't mention the specific

toy that is the subject of the conflict, even though the Wants and Needs may all mention it.

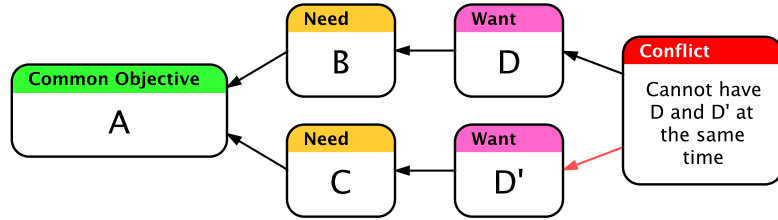

Step 5: Ensure Clarity by Reading the Diagram

Now that the diagram is complete, show the Confidence Spinners, and note that there is only one driver—the Conflict entity. This is the only entity that has no predecessors. If you have set up the document operators and negated one of the edges coming out of the Conflict entity as described above, you will see that by changing the value of the Conflict entity's spinner, one Want or the other can be satisfied (by becoming **True**), and yet the Common Objective can never become **True**. In other words, as long as the conflict exists, the Common Objective cannot be achieved.

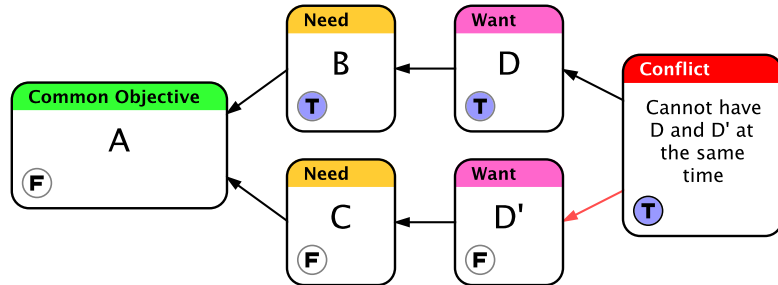

Now read and revise the diagram for clarity and accuracy. Clouds are read from left to right, *against* the flow of the edges, using the pattern:

- "In order to **satisfy the need** we must **obtain our want**."

This is the basic pattern of [Necessary Condition Thinking](#). This pattern applies to all the edges except the two coming from the Conflict entity. Once we have completed this step, we fix or clarify the wording.

Step 6: Identify and Validate Assumptions

In the pattern from the previous step, there are two blanks for needs and wants. In this step we add a third blank:

- “In order to **satisfy the need** we must **obtain our want** because of **our assumptions.**”

Our assumptions are *why* we must obtain our want, and finding erroneous assumptions is the key to breaking the conflict. Assumptions “hide” underneath the Want→Need edges, and the Needs→Common Objective edges. There are also assumptions that underlie the Conflict entity itself— *why* we believe we can’t have both Wants simultaneously.

As you surface these assumptions, use Flying Logic’s annotation feature to add text to each of the four dependency edges and the Conflict entity. Take as much space as you need to describe each assumption, and begin each assumption with “...because”.

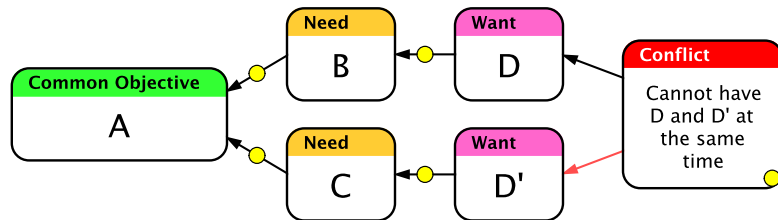

Sometimes there will be a single assumption under each edge, but often there will be several. Assumptions can be either *valid* or *invalid*. Invalid assumptions are often used to link needs to wants, but here you must critically evaluate each of the assumptions to determine their validity. Invalid assumptions can be eliminated, leaving just the valid ones.

Step 7: Propose Solutions

If we manage to invalidate *all* the assumptions on *any* of our edges, then we have eliminated the necessary condition relationship between two of the entities. If we have invalidated all the assumptions on the Conflict entity, then we have eliminated the perception of conflict itself. In either of these cases, the Cloud has “evaporated” and we have discovered there is, in reality, no conflict.

If the cloud is still intact, then we have at least one valid assumption in the five locations. The final step is to construct *solutions* (also called *injections*) that let us “break” one or more of the edges in the Cloud. A solution is an “option for mutual gain,” and the most constructive place in the cloud to find creative solutions is in the edges that connect the Wants to the Needs, by asking questions of this pattern:

- “How can we satisfy **Need** without obtaining **Want**?”
- “How can we accomplish **Common Objective** without satisfying

Need?"

- “How can we obtain both **First Want** and **Second Want?**”

Remember that solutions that you come up with at this stage should not be considered final unless the situation you are analyzing is rather simple— this tool is for brainstorming a new set of options. You can use a [Future Reality Tree](#) to solidify the ideas you generate at this stage. Also, avoid the temptation to look for a single “panacea” solution— you will often need two or more injections to implement a truly win-win solution.

To inject a solution into the diagram, first select the edge where you want the solution to appear then either:

- Double-click the Solution entity in the class list in the sidebar.
- Right-click (Mac or Windows) or control-click (Mac) the edge and select **Solution** from the popup menu that appears.

An **OR** junctor will be inserted into the edge, and the new Solution entity will be added as a predecessor. Give the new Entity a title that summarizes the solution.

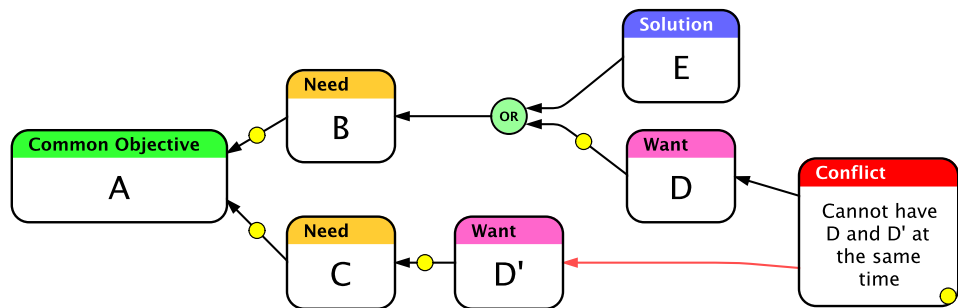

More solutions can be added to the same edge by selecting just the junctor, then using the same command from the popup menu.

By displaying the Confidence Spinners, you will see that you now have additional points of control for every solution you have added,

and that it is now possible to make the Common Objective **True**, even if both Wants (the original positions) are not obtained.

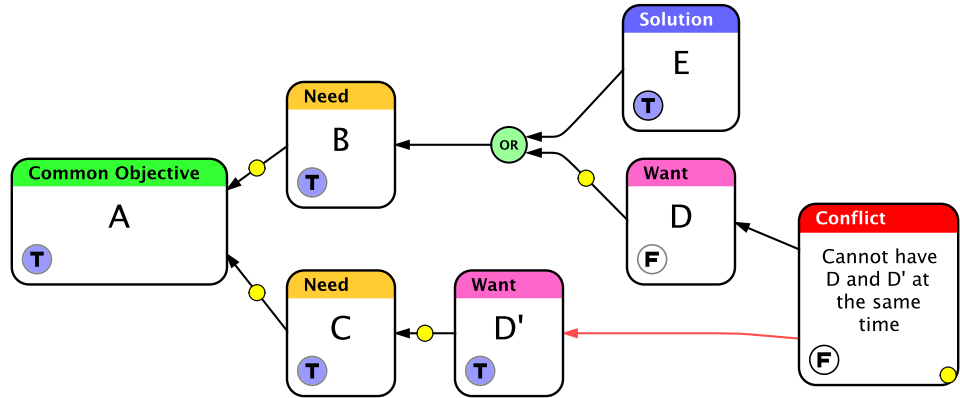

Future Reality Tree

Perhaps you have a system you want to improve, and you've done a [Current Reality Tree](#) to identify *What needs to change*. Perhaps you've also done one or more [Clouds](#) to create some potential win-win solutions, in other words *What to change to*. But...

- How can you be confident which of those ideas will work?
- How do you pick one idea over another?
- How do you know something important hasn't been ignored or overlooked?
- What are the solution's strengths, and how can they be maximized?
- How can you be confident the "solution" won't have unanticipated effects that leave you in a situation that's worse than before?
- Are a potential solution's shortcomings something we can live with, something we can fix after the fact, or something we should avoid at all costs?

It is the job of the Future Reality Tree (FRT) to help you answer these questions.

The FRT is easiest-understood by contrasting it with the Current Reality Tree (CRT):

- To build a CRT, start with a set of Un-Desirable Effects (UDEs), and build down to the Core Driver, from which we invent Solutions (also called **injections**.)
- To build a FRT, start with a potential Solution (injection), and build upwards to a set of Desirable Effects (DEs).

FRTs can be built not only from a previously-conceived Solution, but also from other parts of previously-created CRTs and Clouds.







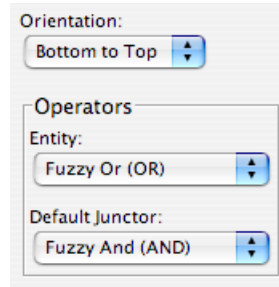





Flying Logic Setup

An FRT is based on [Sufficient Cause Thinking](#), and this is how Flying Logic documents are set up when first created, so you do not need to do anything special with the Operators popup menus to start creating your FRT. Most FRTs are drawn with one or more proposed Solutions at the bottom and the Desired Effects at the top, so you may

want to use the Orientation popup menu to change the orientation of your document to **Bottom to Top**.



FRTs are created using the entity classes in the built-in Effects-Based Planning domain, and primarily use the following classes: Desirable Effect, Un-Desirable Effect, Precondition, Intermediate Effect, and Action. If starting with solutions created from a Cloud, then FRTs will also often use the Solution class from the Conflict Resolution domain.

- | | |
|--|---|
|  • Effects-Based Planning |  • Conflict Resolution |
| •  Goal | •  Want |
| •  Intermediate Effect | •  Need |
| •  Precondition | •  Common Objective |
| •  Action | •  Conflict |
| •  Un-Desirable Effect | •  Solution |
| •  Desirable Effect | |

Step 1: State the Proposed Solution and Desired Effects

Create one or more Solution entities to identify the set of injections you plan to implement. These injections may come from a Cloud you've already created, and you can use the Copy and Paste commands to easily add these entities to your FRT document.

Also create one or more Desirable Effect entities that summarize the outcome you are working towards.

You may wish to temporarily group these two sets of entities to keep them separate— the purpose of the FRT is to fill in the “middle”.

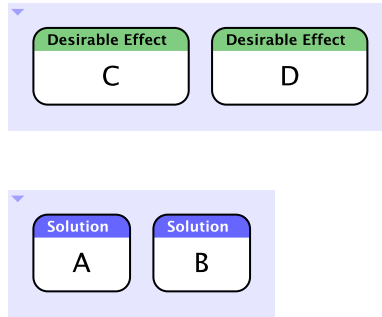

Step 2: Add Other Elements Already Developed

If you have already created a CRT, look for Precondition entities (statements about existing reality) that may be needed in your FRT. You can use the Copy and Paste commands to easily transfer them from your CRT to your FRT.

If you are working from an existing Cloud, also copy over the Common Objective and any of the Needs entities that the proposed Solutions are intended to satisfy.

You may wish to group the entities you’ve added in this step, as they represent entities that will end up in the “middle” of your FRT.

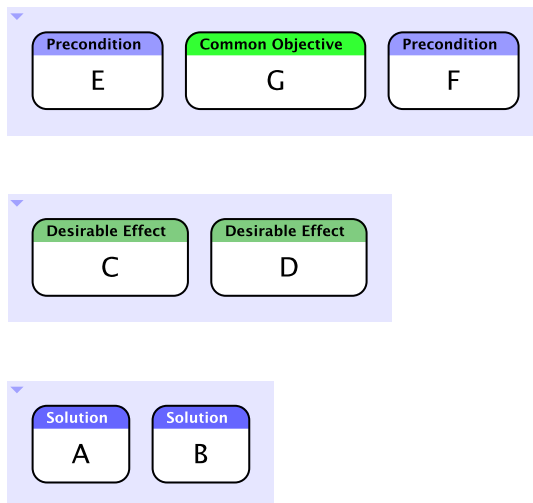

Step 3: Fill In the Gaps

Starting with your Solution entities, add entities that represent the direct, inevitable consequences of those injections being put into place. Use Un-Desirable Effect entities for negative consequences, Desirable Effect entities for positive consequences, and Intermediate Effect entities for neutral consequences.

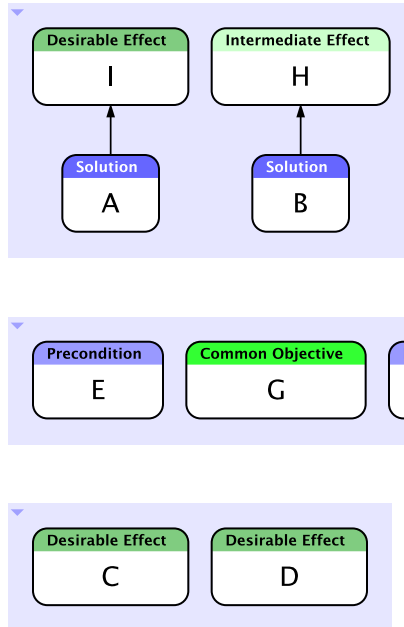

Use the [Categories of Legitimate Reservation](#), to check your causal connections. If the consequences you add are not sufficient by themselves, then make sure you add any Precondition entities, or tie in any other entities that express the other necessary conditions (AND relationships) needed to produce the predicted result. Feel

free to move objects between groups or ungroup the entities when the edges begin giving your document structure.

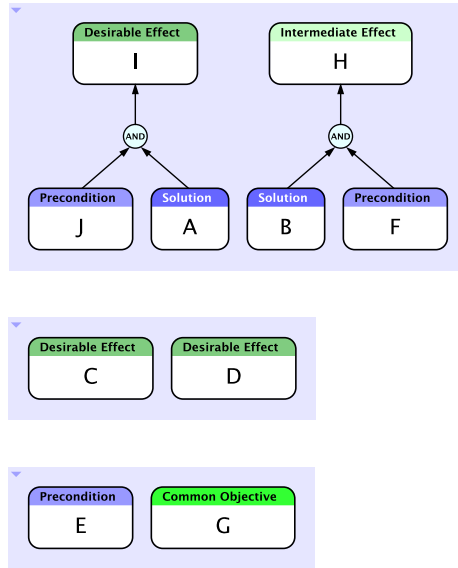

Continue advancing from the effects you've identified to additional effects, evaluating whether the subsequent effects are bringing you closer to any of your Desirable Effects, or the Common Objective or Needs entities you may have added from your Cloud. If they do not, continue adding and evaluating effects you may not have previously considered.

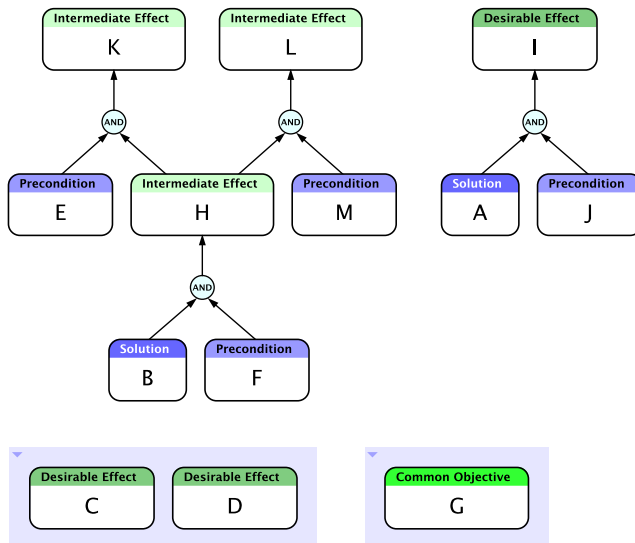

If your progress slows down or stops, then consider additional Action entities you might add. These Actions are also injections, but to differentiate these injections from those that are part of your original solution, use the Action entity class instead of the Solution entity class you started with.

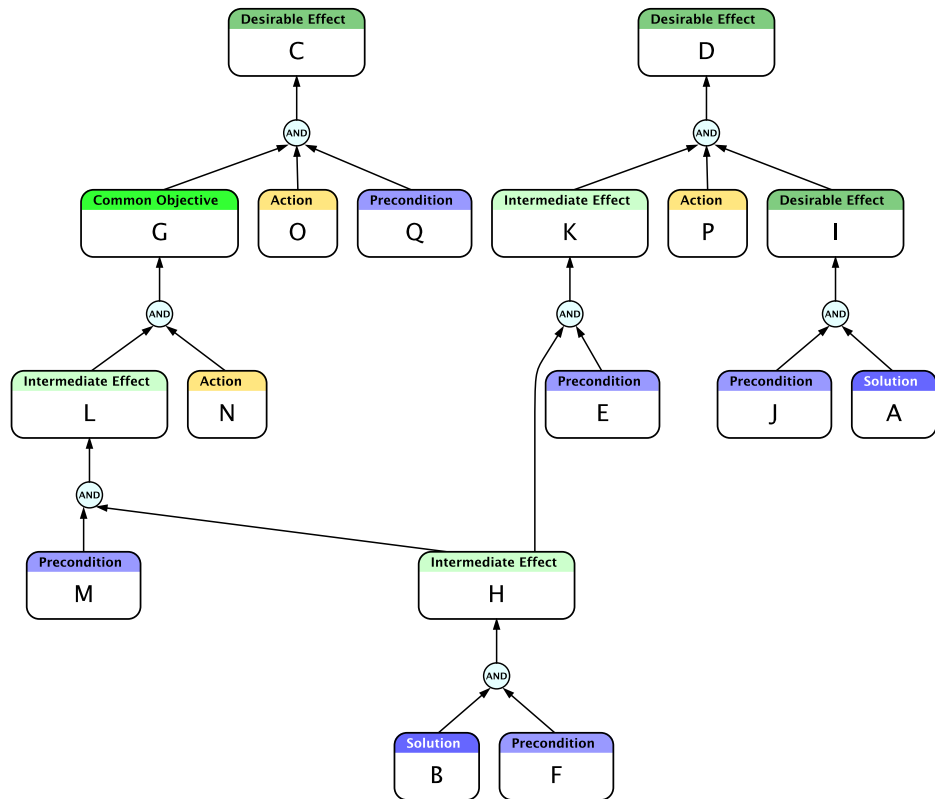

Step 4: Read and Verify the Tree

Once you have made connections to all of your Desirable Effects, re-read the entire diagram. Remember that FRTs are created using Sufficient Cause thinking, so the basic pattern you will use when reading is:

- If **cause A** then **effect B**.

When two or more arrows enter an entity, we have multiple *sufficient conditions*, also called an OR relationship:

- If **cause B** or **cause C** then **effect D**.

When two or more arrows enter an AND junctor, then we have multiple *necessary conditions*:

- If **cause E** and **cause F** then **effect G**.

Pay careful attention to the [Categories of Legitimate Reservation](#). Make sure every statement in your entities and those implied by the causal relationships are clear and logical.

When reading through the diagram, it is also a good idea to display the Confidence Spinners and use them as an aid to checking your logic.

1. Display the Confidence Spinners by clicking the **Confidence** button in the toolbar or selecting the **View ▾ Confidence** command
1. Set every spinner to **indeterminate** by using the **Entity ▾ Reset Confidence** command.
2. Because Preconditions are supposed to be facts about the world, set each Precondition entity's confidence value to **True**.
3. Notice that your Solution by itself is sufficient to cause additional effects, so set its confidence value to **True** and notice how those effects become true.
3. Notice that some of your Actions are "paired up" by AND junctors with other entities that are now **True**. These Actions are **eligible** for execution, while other Actions that are paired up with any entities that are not already **True** are **ineligible** for execution—they must wait until the other necessary conditions become **True**.

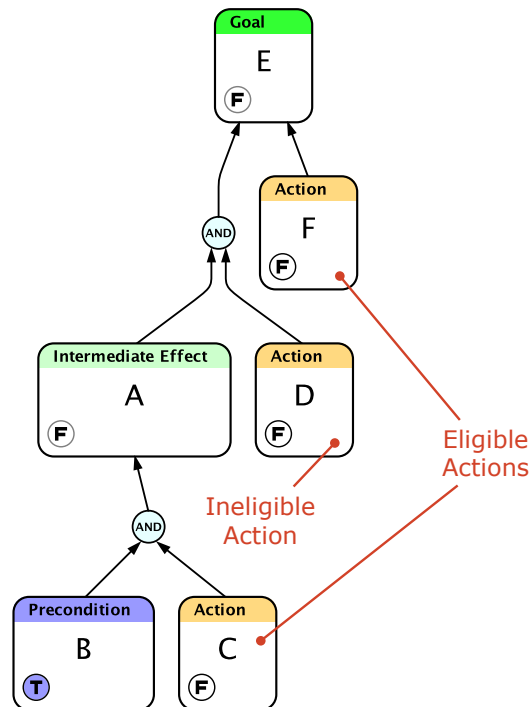

- Continue step-by-step through the diagram, telling yourself the “story” of the diagram as you set each Action to **True** when it becomes eligible, until your Desirable Effects also become **True**. Correct any errors you discover in your logic along the way.

Step 5: Build In Positive Reinforcing Loops

Recall that when building a Current Reality Tree, occasionally there are Un-Desirable effects that are so severe that they “feed back” on others and create negative reinforcing loops. When creating a FRT, you want to loop for opportunities to do the opposite: build in *positive* reinforcing loops. If you can do so, you are more likely to create a solution that is self-sustaining.

Look for Desirable Effects that may intensify effects lower in the tree that lead back to one or more Desirable Effects. If you find such cases, annotate them using [Back Edges](#). Pay close attention to where you might need to add additional Actions in order to create sufficient cause for a positive reinforcing loop’s existence.

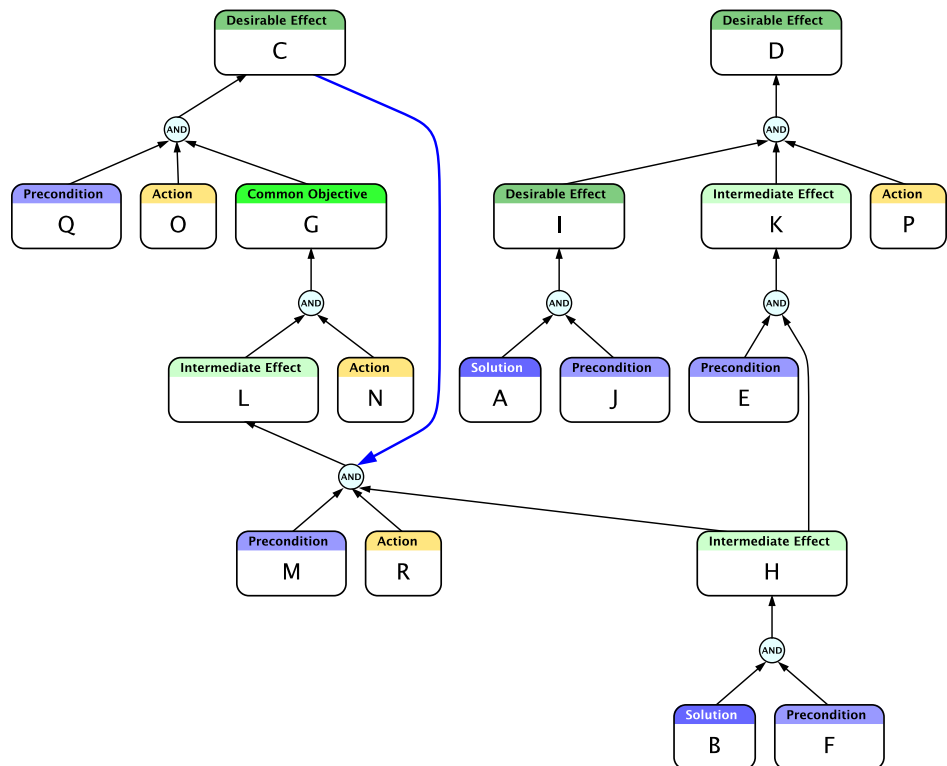

Step 6: Seek and Address Negative Branches

This is a critical step. Whether or not you’ve already added some Un-Desirable Effects to your FRT, now is the time to go back over it and

carefully search for other UDEs that are consequences of any of the entities we have added.

Once you have done that, look for the earliest places in the causal chain where UDEs start to appear. These “turning points” are the start of **Negative Branches**. It is critical that you deal with Negative Branches in order to avoid creating worse problems than those you set out to cure.

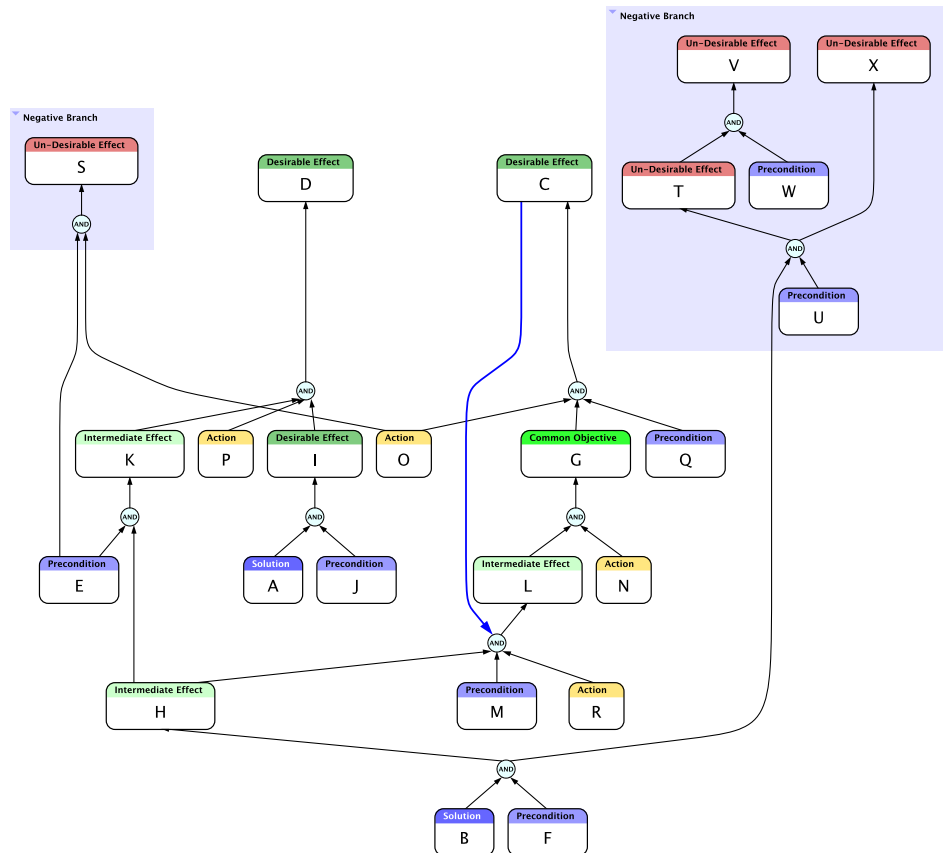

There are two approaches to addressing Negative Branches: **Reactive** and **Proactive**.

In the Reactive approach, UDEs are allowed (perhaps even expected) to occur, but are deemed unavoidable. New Action entities (injections) are then paired with the UDEs (along with other entities as necessary) to cause additional effects that mitigate the UDEs. These additional effects are hopefully Desirable Effects, but can also be neutral Intermediate Effects.

In the Proactive approach, alternative injections are created that achieve the next stage of Intermediate Effects that are on the path

to the final Desirable Effects, *without* causing the UDEs. This is also known as “trimming the Negative Branch.”

In the illustration below, we deal with one Negative Branch *proactively* by discarding one of our original Solution entities **B** and devising an alternate course of action **Y**. The other negative branch is handled *reactively* by devising a new Action **AA** that mitigates the UDE **S** if and when it occurs.

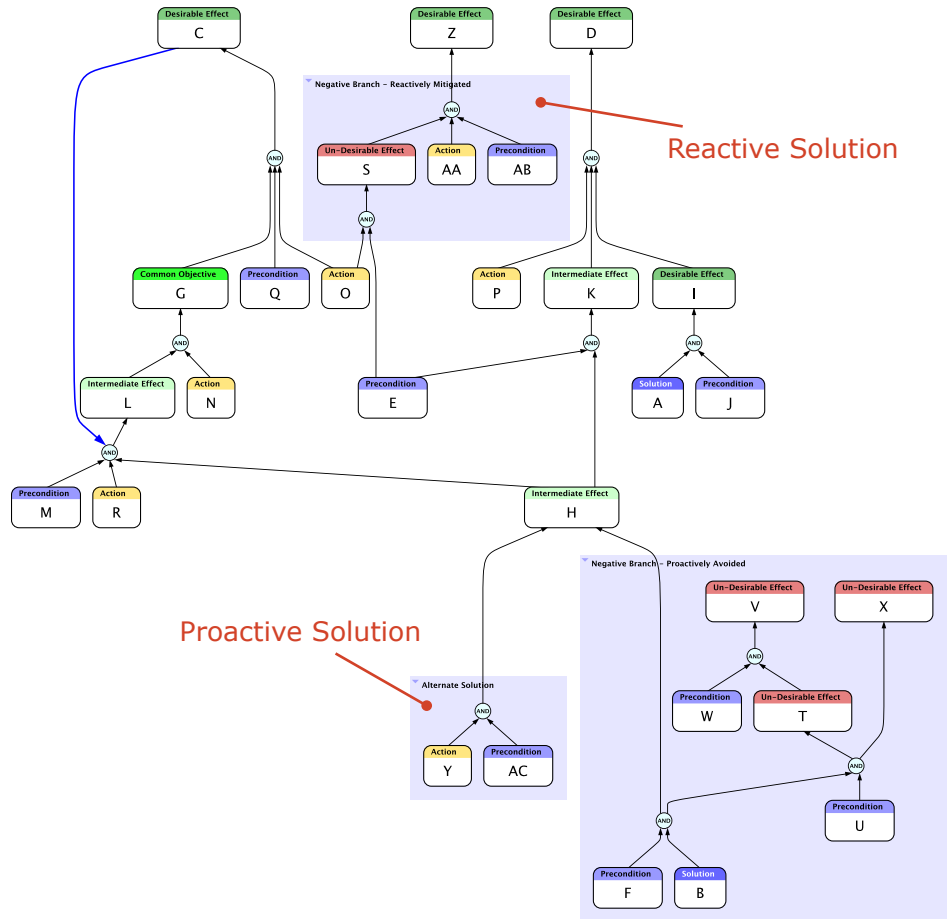

Once a better path has been created, it is a good idea to keep a record of the entities that participated in the Negative Branch by keeping them in collapsed groups, instead of deleting them.

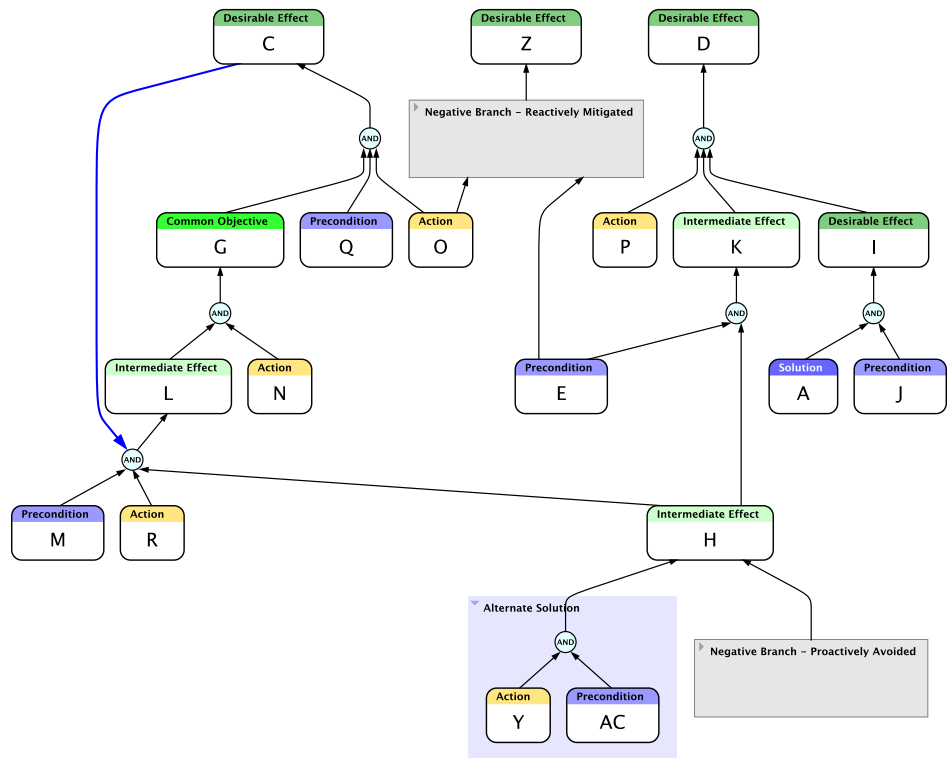

When someone brings you a well-intentioned proposal that you have concerns about, it is good practice to ask for some time to think about it, then take their proposal and construct a FRT with their suggestion as the initial injection at the root, and with the Desirable Effects predicted by the suggester *and* the UDEs you foresee as the final outcome. Once you have this FRT, you can discuss it in detail with the suggester. If you or they can develop injections that address the UDEs, then you are likely to have a proposal you can approve.

Prerequisite Tree

Perhaps you've gotten a picture of your Core Drivers using a Current Reality Tree (CRT). You may have used a Cloud to come up with some promising solutions and used a Future Reality Tree (FRT) to develop a solution you think will work. But unless your situation is quite simple, you're not done yet. One of the most overlooked aspects of planning lies in determining the things we *need* but *don't have yet*: these are the obstacles that lie in our path. And as we develop ways to overcome these obstacles, further obstacles will often become visible. The Prerequisite Tree (PRT) is a tool that helps us to identify and see beyond every obstacle, and make sure that every necessary activity is included in our plan.

Flying Logic Setup

A PRT is based on [Necessary Condition Thinking](#). Since Flying logic documents are set up for Sufficient Cause thinking by default you will want to set the Operator popup menus as follows:

- Entity Operator: Fuzzy And (AND)
- Default Junctor Operator: Fuzzy Or (OR)

PRTs are usually read from top-to-bottom, starting at the Objective(s). However, this means the flow of the edges (arrows) must be towards the Objective(s) or bottom-to-top: so you will want to set the Orientation popup menu to **Bottom to Top**.



PRTs are created using the entity classes in the built-in Prerequisite Tree domain, and use the following classes: Objective, Overcome, and Milestone.

- Prerequisite Tree
- Objective
- Overcome
- Milestone

If you have already constructed PRTs in the past, the choice of **Overcome** instead of **Obstacle** as an entity class name may seem a little strange at first. We use the two terms somewhat interchangeably, but the name *Overcome* was chosen for three reasons:

- First, the choice of *Overcome* makes the tree more natural to read. For example, this simple sequence can be read, “In order to obtain **A**, it is necessary to overcome **B**. In order to overcome **B**, it is necessary to obtain **C**.”



- Second, when using the Confidence Spinners to step through the logic of the tree, we use **True** to indicate that the statement in the title of the entity exists or otherwise pertains to reality, and **False** to indicate that it does not pertain. If we used the class name *Obstacle*, then a **True** confidence value would indicate the *existence of the obstacle*. However, what we want to express is the exact opposite: when all the necessary conditions are met, we want a confidence value of **True** to indicate that the obstacle no longer exists: *it has been overcome*. So when dealing with *Overcome* entities, it is easy to think of **False** meaning, “We have not yet overcome this,” (the obstacle exists) and **True** as meaning, “We have overcome this” (the obstacle no longer exists.) Thus, if every entity in our PRT does not have a Confidence of **True**, it is easy to see at a glance what we still need to accomplish.

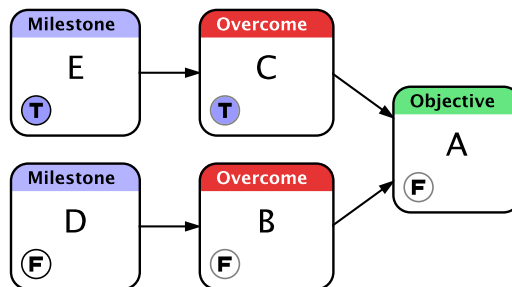

- Third, there is a positive connotation to calling these entities *Overcome*. The name helps convey the idea that all obstacles contain the seeds of their downfall, and focuses the planner on the obstacle not as something that *exists to thwart them*, but rather as something that *exists to be thwarted*.

Step 1: Identify the Objective

Create an Objective entity and give it a title that uses simple, present-tense wording. Usually PRTs will have a single Objective entity that defines the outcome that you are working to achieve, although they can contain more than one Objective if they are closely related. Often the wording of the Objective will be drawn from an injection (Solution entity or Action entity) you used in creating a Future Reality Tree.

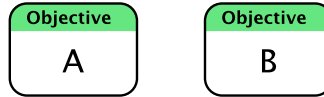

Step 2: Identify Some Obstacles to Overcome

Something stands in the way of achieving your Objective, or you probably would have done it already. Create a set of Overcome entities that represent the *nonexistent* necessary conditions for achieving your Objective. The point here is not to list everything you will need to do to achieve your Objectives, but to identify *the things you still lack*. Connect each Overcome entity as a predecessor of your Objective.

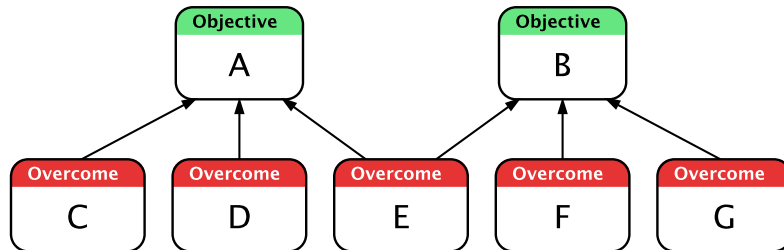

Step 3: Brainstorm Milestones

Consider each of the Overcome entities you have added and brainstorm one or more Milestone entities that will negate the obstacles. It is useful to remember that you don't need to completely destroy an obstacle to get past it: you can (figuratively) go around it, over it, or under it—the point is to be creative.

- Often there will be a single Milestone matched with each Overcome. (**M** is necessary to overcome **G**.)
- Some of the Milestones you identify may Overcome more than one obstacle. (**J** is necessary to overcome **D** and **E**.)
- Other times, your brainstorming will come up with two or more alternatives that may be able to Overcome an obstacle. You use OR junctors to model this. Junctors are easily created by dragging

from an existing entity to a line. (Either **H** or **I** are necessary to overcome **C**.)

- And sometimes, more than one Milestone will need to be achieved in order to Overcome an obstacle. (**K** and **L** are necessary to overcome **F**.)

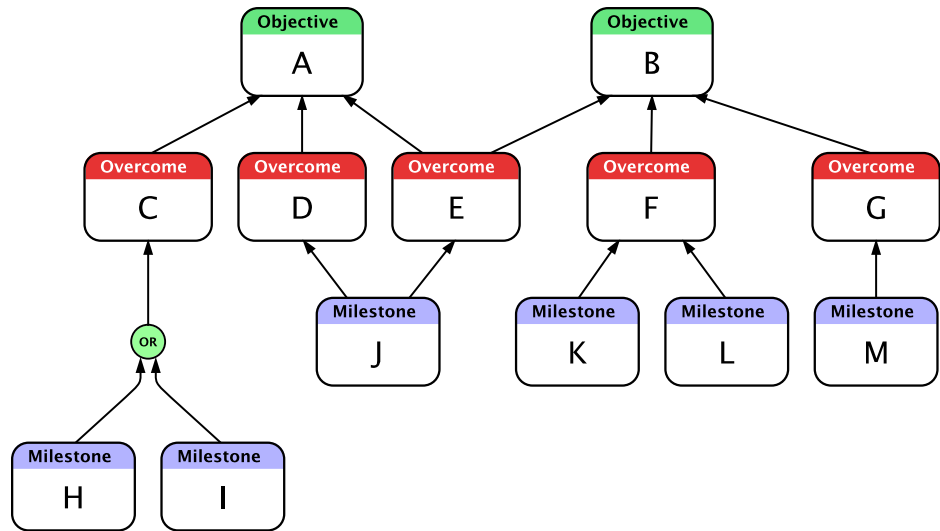

Step 4: Continue to Deepen the Tree

Now consider each of the Milestones you added in the last step. What obstacles to implementing them present themselves? Lack of knowledge? Lack of manpower? Lack of money? Creating a PRT is focused on finding those Necessary Conditions that you currently lack— this is all an obstacle really is. For each such obstacle you identify, create a new Overcome entity and connect it as a predecessor to the appropriate Milestone. For each of these new Overcome entities, devise Milestones that address them, and so on.

As you deepen the tree, the Milestones you add will start to have a smaller, more tractable character. At some point you will add Milestones for which you are unable to find any significant obstacles to their implementation. These Milestones are the roots of your PRT, and represent the accomplishments that must be tackled first. Of course, there may be many actual *Actions* that are required to implement a Milestone, and this is the subject of the Transition Tree discussed in the next chapter. But for now, it is sufficient to identify Milestones that entail no significant obstacles.

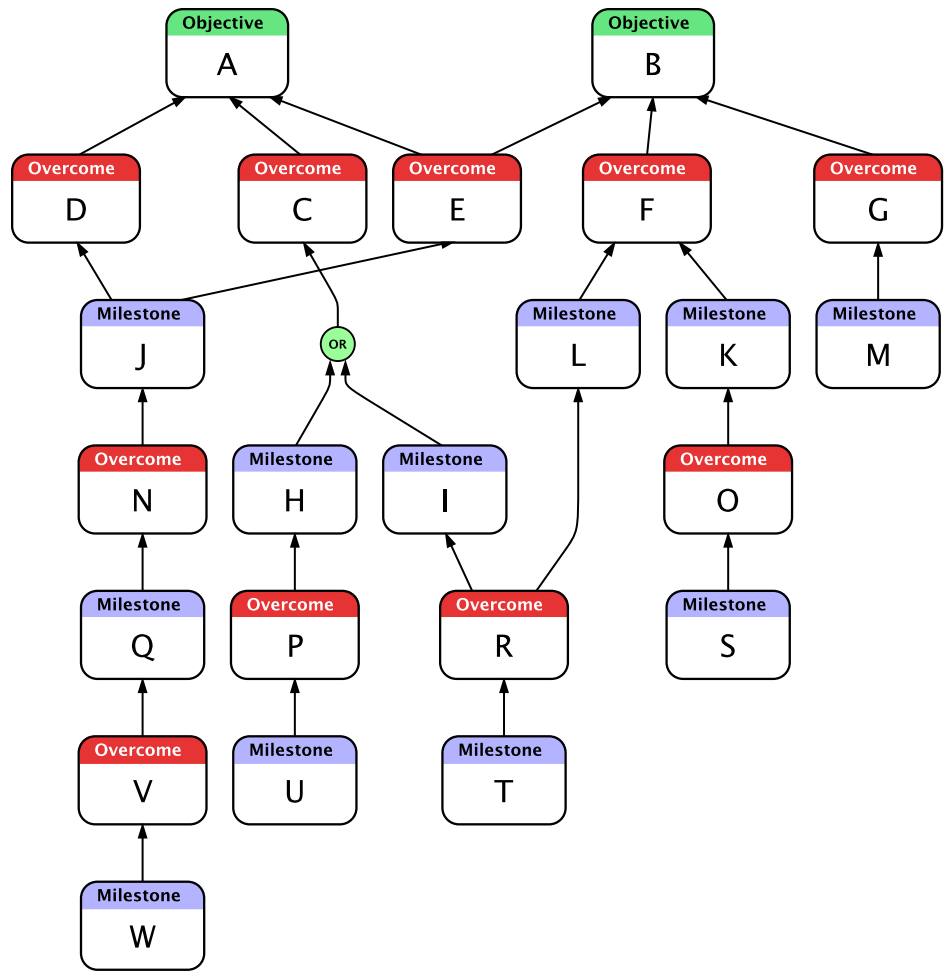

Step 5: Read and Verify the Tree

Once you feel that your tree is well-connected from its simplest Milestones all the way through to the ultimate Objective, it is time to carefully read the tree for clarity and completeness. Since PRTs are constructed using Necessary Condition thinking, the tree is read *against* the flow of the edges starting with the Objective. Each step of the tree is read with one of the following patterns:

- In order to obtain **A** it is necessary that we overcome **B**.
- In order to overcome **B** it is necessary that we obtain **C**.

Make sure that you apply the Categories of Legitimate Reservation as you read through the tree. Ask yourself questions such as:

- Do we really need to overcome this obstacle?
- Is there a way to avoid having to overcome this obstacle?

- Does the milestone really overcome the obstacle?
- Are there any other milestones required to overcome the obstacle?
- Are there any other milestones that are also sufficient to overcome the obstacle?

It is also a good idea to use Flying Logic's Confidence Spinners at this stage to go through your diagram step by step *with* the flow of the edges from the root Milestones all the way to the Objective.

Step 6: Trim and Finalize the Tree

Once you have verified that your PRT is logically sound, it may contain one or more alternate Milestones (connected by OR relationships) that you can now choose among. Trim the rejected alternatives either by deleting them or placing them within collapsed groups.

Transition Tree

Once you have identified the obstacles that stand in the way of achieving your goal and developed milestones that will overcome them, you need an execution plan: a set of actions that combine step-by-step to bring your system inexorably closer to its goal. Others who read your plan (and ideally participated in its creation) should be able to clearly see how every action, and particularly the actions in which they play a role contribute to the benefit of the entire system. This is the key to creating **buy in**— a shared vision that yields enthusiastic cooperation. The Transition Tree (TRT) is an effective tool for creating an execution plan that creates a transition from the *current reality* to a *future reality*.

Although a Transition Tree is related to the more traditional [PERT diagram](#) used in Project Management in that they both contain a set of sequenced actions, one of their main distinctions is the TRT's inclusion of Preconditions (assumptions about reality) paired with each action. This means that TRTs can contain numerous contingency plans that are triggered by the Preconditions that pertain at the time the plan is executed. Essentially, as execution of the plan proceeds, numerous different PERT charts can "fall out" of a TRT depending on what the situation "on the ground" looks like. This makes the TRT an ideal tool for creating plans that involve a significant degree of risk.

Flying Logic Setup

A TRT is based on [Sufficient Cause Thinking](#), and this is how Flying Logic documents are set up when first created, so you do not need to do anything special with the Operators popup menus to start creating your TRT. TRTs often flow upwards, with the Goal at the top. So you may want to use the Orientation popup menu to change the orientation of your document to **Bottom to Top**.

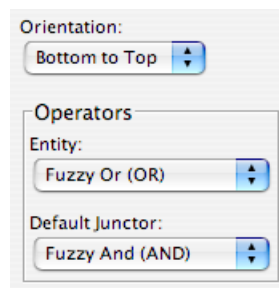

TRTs are created using the entity classes in the built-in Effects-Based Planning domain, and primarily use the following classes: Goal, Precondition, Intermediate Effect, and Action. You can also use Desirable Effect entities to highlight other positive benefits of your plan,

and Un-Desirable Effect entities if your sequence of actions causes unavoidable UDEs that further part of the execution plan must address.

- Effects-Based Planning
 - Goal
 - Intermediate Effect
 - Precondition
 - Action
 - Un-Desirable Effect
 - Desirable Effect

Step 1: Identify the Goal

A TRT often contains a single Goal entity, but can contain more than one if they are reasonably related. You can start a TRT with an intuitive pre-conception of what your Goal should be, or you can start with your Goal taken from one of the injections taken from a Future Reality Tree, or an Objective taken from a Prerequisite Tree. In any case, the Goal entity should have as its title a clear, present-tense statement of the desired reality.

Step 2: Identify Intermediate Effects

If you have already done a Prerequisite Tree, you have a set of Milestone entities that you can copy directly into your Transition Tree document. It's important to realize, however, that while the Milestones in a PRT are all *necessary*, they probably aren't sufficient. The PRT is used for identifying and overcoming *the things you don't have yet*, while the TRT is used for identifying *everything* you need to do, and the order in which you need to do them.

If you are not copying Milestone Entities from a PRT, you may want to create a number of Intermediate Effect entities that represent states you know will need to achieve along the way to your goal, and link them with edges to their order is more or less defined. It is not

necessary to be absolutely rigorous at this stage— defining the exact causal sequence is the focus of the following steps.

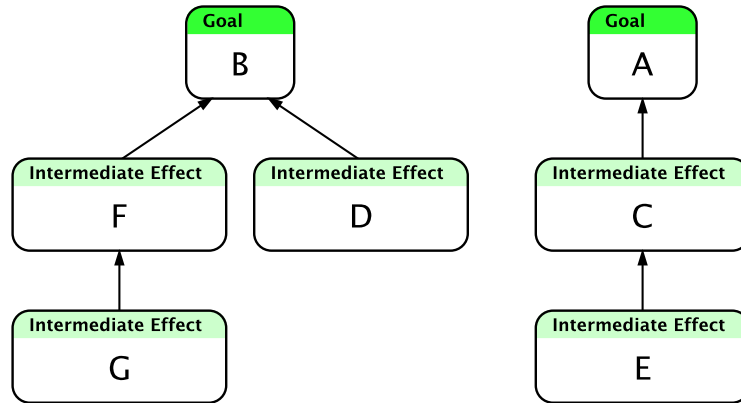

Step 3: Define a Complete Step

A *step* of your execution plan requires three things:

- The outcome you want to achieve. This is either an Intermediate Effect, a Milestone copied from a PRT, or the Goal of your TRT.
- A statement of current reality. This is either a Precondition entity, which represents an aspect of reality that is out of your control and which must therefore be taken as a given, or an Intermediate Effect or Milestone that was the outcome of a previous step.
- An Action. To be well-defined, an Action must be something within your control or influence, with clear criteria for determining that it has been carried out successfully, and must be something that can be assigned to a resource with the responsibility and power to carry it out.

The current reality and action must logically combine as the necessary and sufficient causes of achieve the outcome.

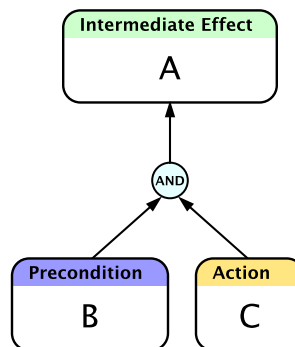

If in reading your step, the action is not sufficient to produce the outcome, then it needs to be broken down into one or more sufficient sub-steps.

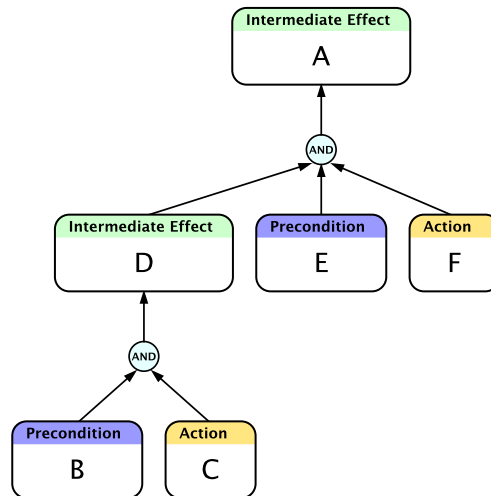

Step 4: Continue Building the Tree

Each of the intermediate effects in your TRT must similarly be characterized as complete *steps*: outcome of actions and current realities. Often these steps will form a linear sequence, but other times they will diverge into parallel sequences, or have more complex dependencies.

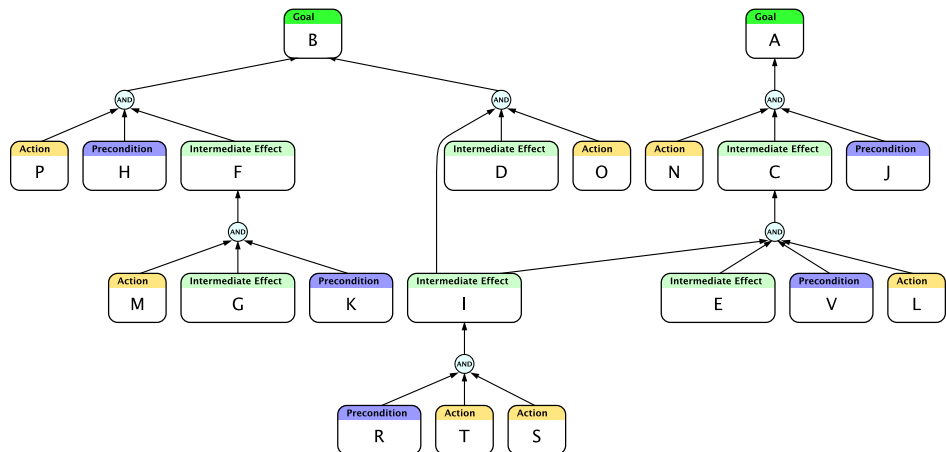

Step 5: Seek and Address Negative Branches

This is similar to the step of the same name in the description of the [Future Reality Tree](#) (FRT). In fact, a TRT can be thought of as a kind of FRT where instead of starting with an injection and ending up with the consequences, you start with a desired consequence (the Goal) and work backwards to the injections that will achieve it.

If you are working from a FRT you created previously, then your actions may already be designed to avoid the Un-Desirable Effects (UDEs) that are the hallmarks of negative branches.

On the other hand, sometimes it is impossible to avoid risk. Risk manifests as the failure of Preconditions (assumptions about reality) to be **True** when it comes time to execute the actions that depend on them. Depending on the nature of the environment in which the plan is executed, exactly *which* Preconditions may not hold true at the time the plan is executed can be very difficult to predict, and if you create a plan with a rigid picture of reality, you are likely to be disappointed when reality fails to conform. Thus, to the degree that your plan involves risks, it is critically important that you identify the UDEs that can result from the failure of Preconditions, and develop alternative courses of action that either mitigate those UDEs (the *reactive* approach) or avert them (the *proactive* approach.)

If a plan terminates with any un-addressed UDEs, it is *incomplete*.

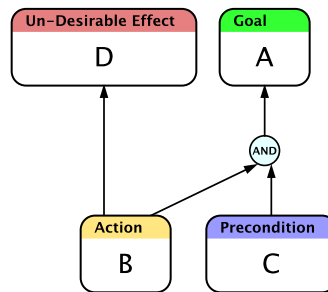

Incomplete Plan

A *complete* plan will terminate only with Goals or Desirable Effects.

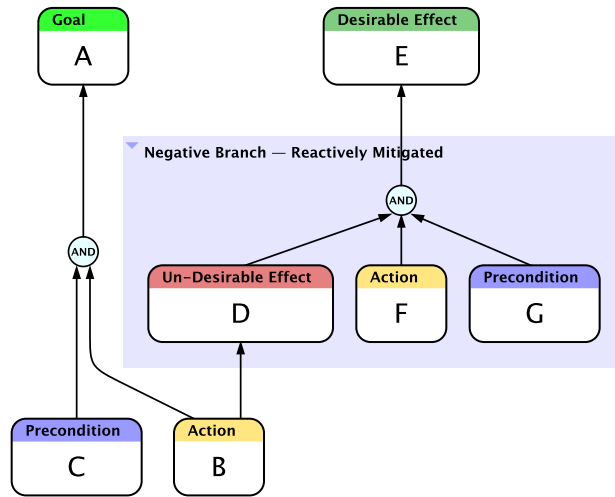

Complete Plan — Reactive Mitigation

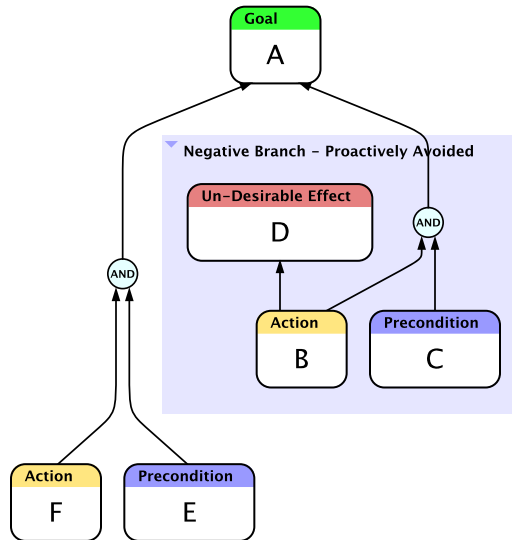

Complete Plan — Proactive Avoidance

Finally, what happens if all the conditions determined to be necessary and sufficient for a particular effect are *present*, but when the plan is executed the effect turns out to be *absent*? What if some other UDE we didn't anticipate manifests? More importantly, how can we reduce the chances of this nightmare from occurring?

This is the case of **unforeseen uncertainty** (also called **unknown-unknowns**)— things that have not been and could not have been

imagined or anticipated. In this case there can be no pre-determined contingency plan, but there are some things we can do to prepare:

- If possible, try several approaches in parallel and ultimately commit to the one that works the best.
- Avoid hubris: nurture an organizational culture of humility and resist being blinded by your own expertise.
- Be flexible and willing to adapt the plan to a changing situation.
- Give heed to hunches and concerns of experienced stakeholders, even if those reservations are not (for the moment) clearly articulated.

For the last case, even inarticulate reservations can be added to a TRT as unspecified Preconditions, and removed later if they fail to materialize. Don't add unknown-unknowns at every possible place—just where a strong-but-inspecific reservation has been expressed. Unknown-unknowns can also be added as part of assessment when planned effects fail to materialize as a plan is executed.

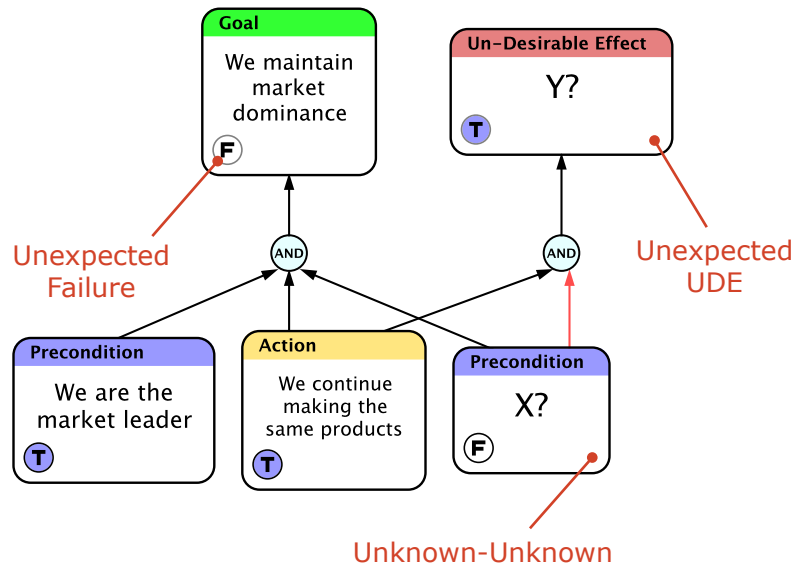

Step 6: Read and Verify the Tree

This is similar to the step of the same name in the description of the Future Reality Tree (FRT). If you have included contingency plans, then step through the pertinent parts of your tree more than once, each time setting up your Preconditions to trigger the different paths through your tree.

Strategy & Tactics Tree

The latest addition to the TOC-TP application tools, the Strategy and Tactics Tree (S&T Tree) is used to move from the highest-level organizational goals to a comprehensive, multi-tiered, fully-justified set of implementation steps. It is used to implement a wide-ranging improvement throughout a larger organization by making it clear what role every part of the organization plays.

Flying Logic Setup

An S&T Tree is based on [Necessary Condition Thinking](#). Since Flying logic documents are set up for Sufficient Cause thinking by default you will want to set the Operator popup menus as follows:

- Entity Operator: Fuzzy And (AND)
- Default Junctor Operator: Fuzzy Or (OR)

S&T Trees are usually read from top-to-bottom, starting at the highest-level Strategy. However, this means the flow of the edges (arrows) must be towards the highest-level Strategy or bottom-to-top: so you will want to set the Orientation popup menu to **Bottom to Top**.

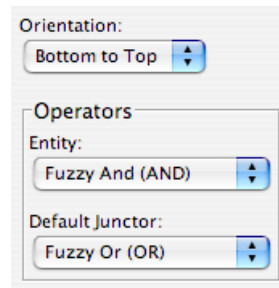

Orientation:
Bottom to Top

Operators

Entity:
Fuzzy And (AND)

Default Junctor:
Fuzzy Or (OR)

S&T Trees are created using the entity classes in the provided domain file **Strategy & Tactics Tree.logic-d** in the **Examples/Strategy & Tactics Tree** folder. You can either import this domain into an existing document with the **Entity** **Import Domain** command, or open it with the **File** **Open** command, in which case it acts like a template document and opens a new, untitled document with the S&T Tree domain already imported and ready for use.

- ◻ Strategy & Tactics Tree
- ◻ Strategy
- ◻ Tactic
- ◻ Parallel
- ◻ Necessary
- ◻ Sufficient

Structure of the S&T Tree

The S&T Tree is based on the idea that **Strategy** and **Tactics** are complementary concepts used to describe a tree-like hierarchy of action, with each *Step* (node) of the tree justifying its existence with a strategy: a description of *why* the node exists. The highest-level strategy corresponds to the system's goal.

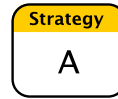

Each Strategy is supported by a single Tactic entity that describes *how* the strategy will be implemented. The bottom of a complete S&T tree will always be a layer of Tactics— the most fundamental actions that support the strategies.

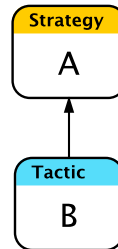

If more than one Tactic is necessary to implement a Strategy, a Tactic may be broken down into two or more sub-Tactics, but each one must first be justified by its own Strategy. Therefore, each Strategy

always has *exactly one* Tactic below it, but tactics may have either *zero*, or *two or more* sub-Strategies.

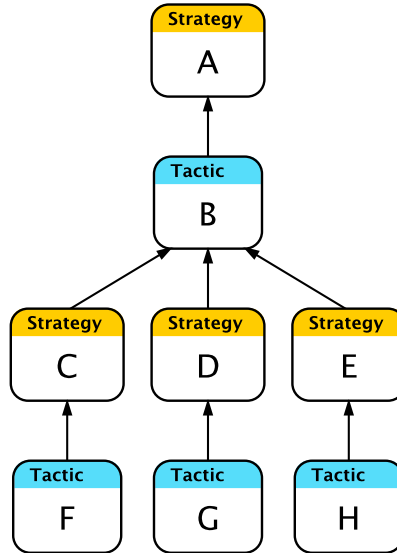

If a Strategy has more than one possible Tactic that can accomplish it, then this can be added as an OR relationship.

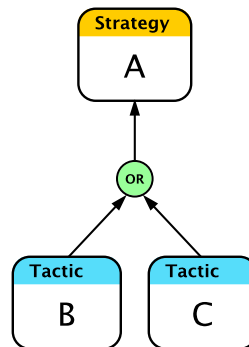

For a given Strategy, we need to do more than provide a Tactic for accomplishing it— we also need to justify that Tactic as both *necessary* and *sufficient* to accomplish its parent strategy. So we create a **Necessary** entity and a **Sufficient** entity and make each one a sibling of each Tactic entity. The title given to each entity should do exactly as the class name suggests: describe why the Tactic *must* be implemented to accomplish the strategy (Necessary), along with why that Tactic absolutely *will work* (Sufficient). If there are numerous justifications for why a Tactic is Necessary or Sufficient, then

additional Necessary or Sufficient entities can be added, or they can be enumerated in the entity's textual annotations.

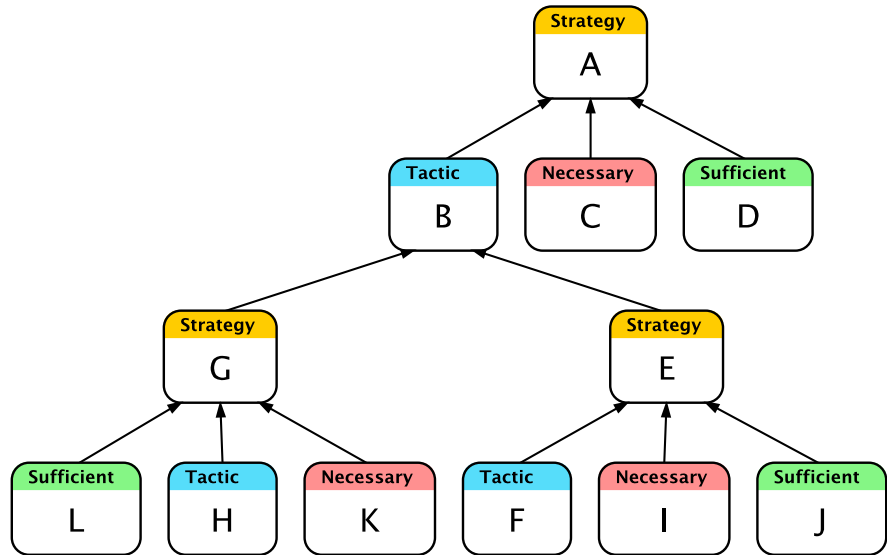

One more entity class, the **Parallel** (“parallel assumption”) class is used to proactively answer objections that neither directly address the Necessity or Sufficiency of the Tactic, such as:

- The Strategy already exists— no action need be taken to implement it.
- It is not possible to implement the Tactic.

Taken together, all five kinds of entities constitute a **Step**.

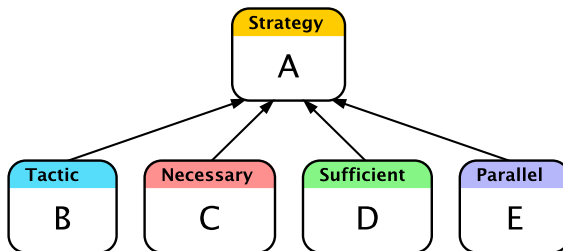

Since S&T Trees can grow quite large, it is useful to use Flying Logic's grouping feature to manage the diagram. One approach is to group all a Strategy's supporting entities and use a junctor to combine

their edges with an AND junctor so only a single edge emerges from the group.

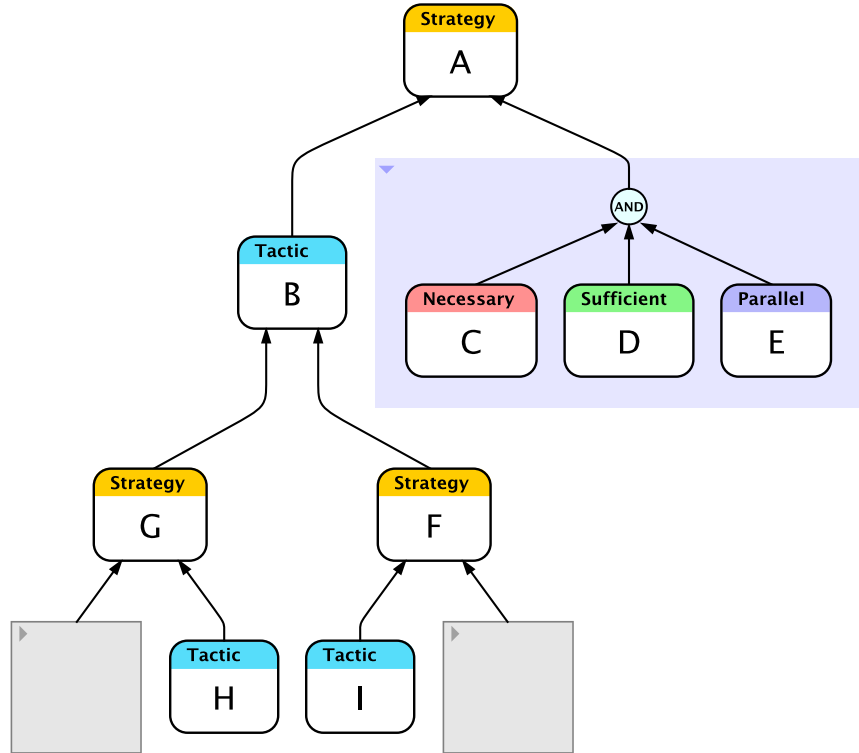

Groups can, in turn, be used to group entire Steps, including the Strategy entity, the Tactic entity, and the sub-group containing the Necessary, Sufficient, and Parallel (NSP) entities. Using this tech-

nique, you can arrange a very large S&T Tree to make it easy to “drill down” to the level of detail you need. Take these ideas as suggestions, and feel free to develop your own techniques for managing large Flying Logic diagrams.

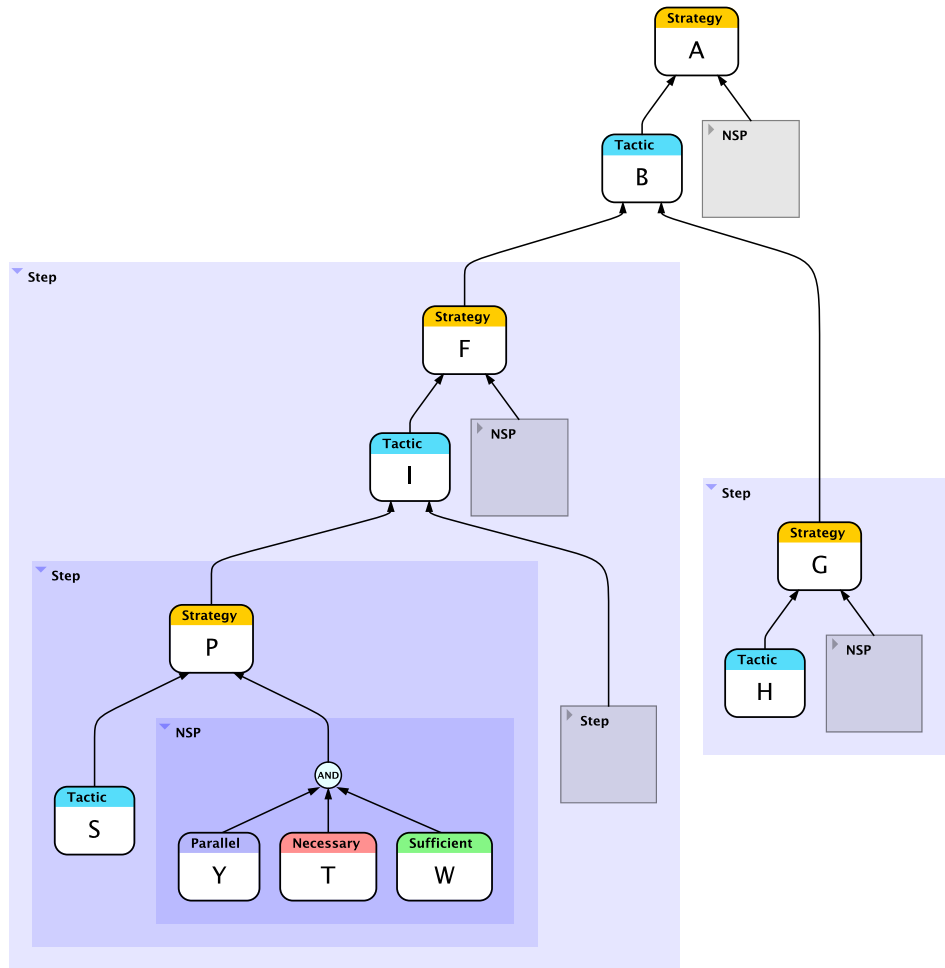

Part III — Other Techniques

Evidence-Based Analysis

PRO This category of entity classes is suited to an environment when a more probabilistic mode of analysis is desired. One real-world scenario where Evidence-Based Analysis is useful is in [Competitor Analysis](#). Usually an analysis is designed and then carried out over a period of time. During such time, Propositions may be discovered to hold, which may trigger further actions by the agency conducting the analysis.

Flying Logic Setup

There are two styles of Evidence-Based Analysis: **belief-network** and **probabilistic**. If the belief-network style is used, the Flying Logic document is set up with Proportional ($::$) for both the entity operator and default junctor operator. If the probabilistic style is chosen, the document is typically set up with Sum Probabilities (\oplus) as the entity operator and Product (\times) as the default junctor operator. This setup is analogous to the use of Fuzzy Or (OR) and Fuzzy And (AND) in [Sufficient Cause Thinking](#).

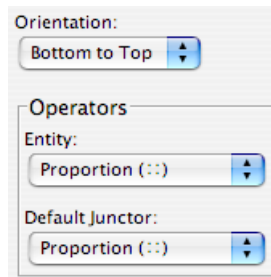

Orientation:
Bottom to Top

Operators

Entity:
Proportion ($::$)

Default Junctor:
Proportion ($::$)

Setup for Belief Network

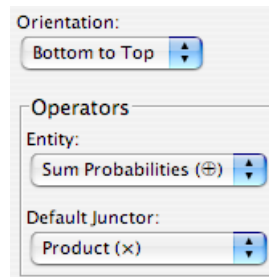

Orientation:
Bottom to Top

Operators

Entity:
Sum Probabilities (\oplus)

Default Junctor:
Product (\times)

Setup for Probabilistic

Proposition

Propositions (also known as *requirements*) are questions for which the analysis is intended to discover the most likely answers. Propositions take the form of a statement that has some probability of being true. Determining whether the probability of the Propositions exceeds determined thresholds is a primary purpose of Evidence-Based Analysis. Propositions are analogous to goals in Effects-Based Planning, and thus are *terminal*, i.e., they are always successors and never predecessors.

Proposition

Our competition will introduce new product line in less than six months

Indicator

Indicators are potential causes for Propositions or other Indicators, and can be considered analogous to Intermediate Effects in Effects-Based Planning. Another way of thinking of Indicators is as inferred evidence. Each Proposition typically has a set of Indicators that feed into it, each of which is considered to be a possible cause of the Proposition, and which together form a “template” for recognizing that the Proposition holds (i.e., that the *requirement has been met.*)

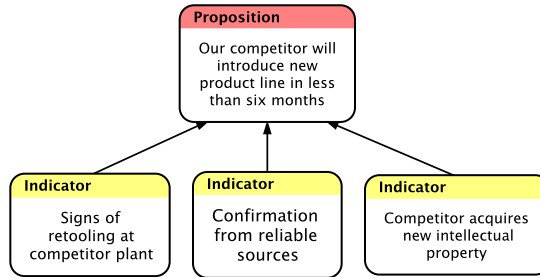

Each indicator in turn may have a set of more specific indicators which feed into it and form a “sub-template” for recognizing that the indicator in question probably holds. Indicators are usually both successors and predecessors.

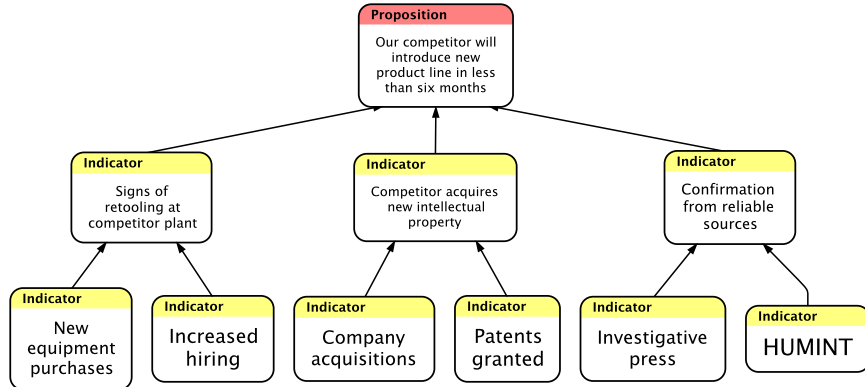

In a complex analysis, individual analysts can be assigned responsibility for certain indicators, which places them in a supervisory role over all indicators that are predecessors of the indicators for which they are directly responsible.

Event

Events represent direct evidence which becomes known throughout the life cycle of the analysis. In the intelligence community for example, Events may be derived from Signals Intelligence ([SIGINT](#)), Hu-

man Intelligence ([HUMINT](#)), or Open Source Intelligence ([OSINT](#)).

Events are always predecessors and are never successors. They are assigned a Confidence value based on their *reliability* (or probability.)

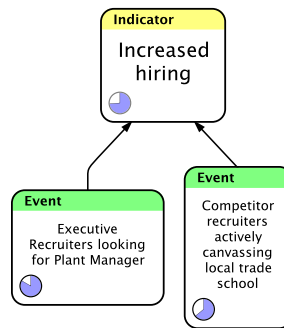

Knowledge

Knowledge represents pertinent facts known to be true about the situation under analysis. Knowledge can be built into the analysis before events are received, or can be added to the analysis in response to events as they occur. Knowledge entities are combined with Events to provide context and semantics either supporting or refuting the various indicators into which they feed.

Like Events, Knowledge entities are predecessors and not successors. They are assigned Confidence values based on their reliability (or probability.)

Edge Weights

Edge weights in the model are assigned based on the positive (or negative) *correlation* between each entity and its successors.

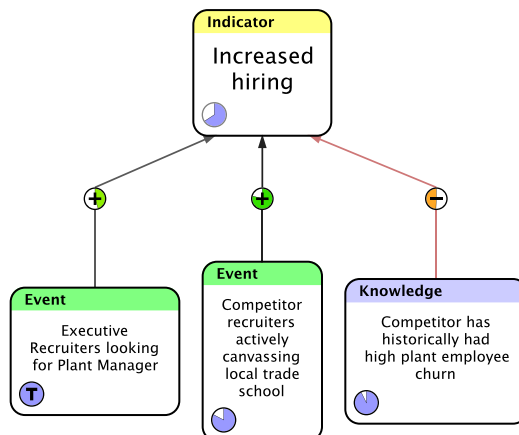

Concept Maps

Concept Maps are used to visualize and capture or convey a quick understanding of a web of related concepts.

Flying Logic Setup

Concept Maps are created using the entity classes in the provided domain file **Concept Map.logic-d** in the **Examples/Concept Maps** folder. You can either import this domain into an existing document with the **Entity ▶ Import Domain** command, or open it with the **File ▶ Open** command, in which case it acts like a template document and opens a new, untitled document with the Concept Map domain already imported and ready for use.

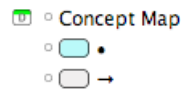

Structure of Concept Maps

Concept maps use two entity classes, **Concept (•)** and **Relation (→)**. Symbols were used for the entity class names instead of words because Concept Maps are read entirely from their entity titles, and the words "Concept" and "Relation" are never spoken.

Concepts Maps start with one or more main concepts at the root, and relations are used between concepts to connect in supporting concepts. The main rule when building Concepts Maps is that each Concept→Relation→Concept step should be readable as a complete sentence. Additional relevant concepts can be added in any order, and connected in as many places as they are used.

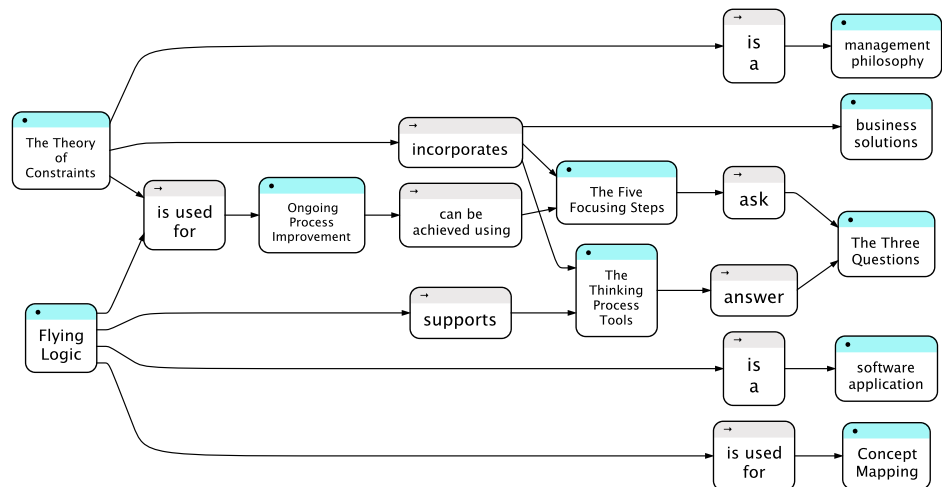

Appendix

Resources

Flying Logic Web Site

The resources at toc-goldratt.com are intended to be of interest not only to Flying Logic users, but also to people generally interested in TOC, business improvement, and personal improvement.

- [Flying Logic Forum](#) — Discussion
- [Flying Logic Wiki](#) — Collaborative knowledge base
- [Flying Logic Blog](#) — News and items of interest

Web Sites on the TOC

- [A Guide to Implementing the Theory of Constraints](#)
Kelvyn Youngman
- [TOC Video Overviews](#)
Dr. James R. Holt, Washington State University
- [My Saga to Improve Production](#)
By Eli Goldratt
- [Theory of Constraints International Certification Organization](#)
— Among other things, the TOC-ICO hosts a yearly conference
- [TOC Glossary](#)
Pinnacle Strategies
- [Strategy and Tactics](#) — a description of the S&T Tree
By Eli Goldratt, Rami Goldratt, and Eli Abramov
- [Throughput Accounting](#) — includes a description of Throughput, Inventory, and Operating Expense
Wikipedia

Books on the TOC

- [Breaking the Constraints to World-Class Performance](#)
by H. William Dettmer
- [Thinking for a Change: Putting the TOC Thinking Processes to Use](#)
by Lisa J. Scheinkopf
- [Introduction to the Theory of Constraints \(TOC\) Management System](#)
by Thomas B. McMullen, Jr.

Books on Psychology, Communication, and Negotiation

- [Mistakes Were Made \(But Not by Me\): Why We Justify Foolish Beliefs, Bad Decisions, and Hurtful Acts](#)
by Carol Tavris, Elliot Aronson
- [Getting to Yes: Negotiating Agreement Without Giving In](#)
by Roger Fisher, Bruce M. Patton, William L. Ury
- [Getting Past No: Negotiating in Difficult Situations](#)
by William L. Ury
- [Difficult Conversations: How to Discuss what Matters Most](#)
by Douglas Stone, Bruce Patton, Sheila Heen, Roger Fisher
- [Crucial Conversations: Tools for Talking When Stakes are High](#)
by Kerry Patterson, Stephen Covey et al.

Other Useful Web Sites

- [The Theory Underlying Concept Maps and How To Construct Them](#)
by Joseph D. Novak, Alberto J. Cañas, Florida Institute for Human and Machine Cognition